

Extension Card

Safety Card STO

User Manual

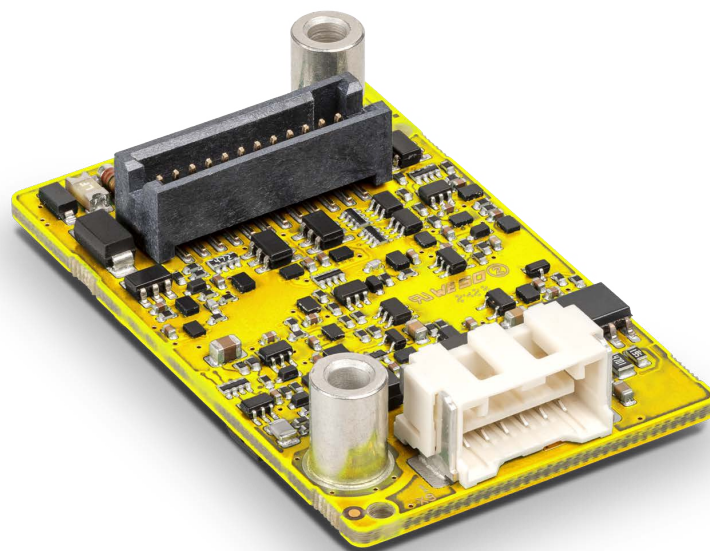

[epos.maxongroup.com](https://www.epos.maxongroup.com)

TABLE OF CONTENTS

1	ABOUT	5
1.1	About this document	5
1.2	About the device	7
1.3	About the safety precautions	8
2	SAFETY	11
2.1	Introduction	11
2.2	Main features	11
2.3	Control modes and reset	12
3	SYSTEM OVERVIEW	13
3.1	Introduction	13
3.2	Modularity and combinations	14
4	SPECIFICATIONS	15
4.1	Technical data	15
4.2	Dimensional drawing	16
4.3	Standards	17
5	SETUP	19
5.1	Generally applicable rules	19
5.2	Requirements for mechanical installation and commissioning	19
5.3	Assembly instructions	20
5.4	Assembly process	20
5.5	Status indicators	21
6	CONNECTIONS	23
6.1	Signal interface (X200)	23
6.2	STO (X9)	24

READ THIS FIRST

These instructions are intended for qualified technical personnel. Prior commencing with any activities...

- you must carefully read and understand this manual and
- you must follow the instructions given therein.

The Safety Card motion controller is considered as safety component according to EU Directive 2006/42/EC, Article 2, Clause (c) and is intended to be incorporated into or assembled with other machinery or other safety component or equipment.

Therefore, you must not put the device into service,...

- unless you have made completely sure that the other machinery fully complies with the EU directive's requirements!
- unless the other machinery fulfills all relevant health and safety aspects!
- unless all respective interfaces have been established and fulfill the herein stated requirements!

7	MAINTENANCE AND PARTS	27
7.1	Maintenance procedures	27
7.2	Easy and safe troubleshooting	27
7.3	Test intervals where relevant	28
7.4	Life mission time	28
	DECLARATION OF CONFORMITY	29
	LIST OF FIGURES	31
	LIST OF TABLES	32
	INDEX	33

••page intentionally left blank••

1 ABOUT

1.1 About this document

Note: *The present document is the «Original Instruction», and all translations should be clearly labeled as «Translation».*

1.1.1 Intended purpose

The purpose of the present document is to familiarize you with the Safety Card STO. It will highlight the tasks for safe and adequate installation and/or commissioning. Follow the described instructions ...

- to avoid dangerous situations,
- to keep installation and/or commissioning time at a minimum,
- to increase reliability and service life of the described equipment

1.1.2 Target audience

The Safety Card STO and therefore this present document is intended for trained and skilled personnel. It conveys information on how to understand and fulfill the respective work and duties.

1.1.3 How to use

Throughout the document, the following notation and code is used.

Notation	Meaning
(n)	refers to an item (such as part numbers, list items, etc.)
«Abcd»	indicating a title or a name (such as of document, product, mode, etc.)
(0123)	refers to an item (such as part numbers, list items, etc.)
→	denotes “see”, “see also”, “take note of” or “go to”

Table 1-1 Notation used

Short form	Meaning
BLDC Motors	Brushless DC Motors
CAN	Controller Area Network
DC	Diagnostic Coverage
EC Motors	Electronically Commutated Motors
EMC	Electromagnetic Compatibility
ESD	Electrostatic Discharge
I2C	Inter-integrated circuit
MTTFd	Mean Time To Dangerous Failure
OSSD	Output Signal Switching Device

Continued on next page.

Short form	Meaning
PDS (SR)	Power Drive Systems (Safety Related)
PELV	Protective Extra Low Voltage
PFH _d	Probability of Dangerous Failure per Hour
PL	Performance Level
PPE	Personal Protective Equipment
PWM	Pulse Width Modulation
SELV	Safety Extra Low Voltage
SRP/CS	Safety-Related Parts of Control System
STO	Safe Torque Off

Table 1-2 Abbreviations used

1.1.4 Symbols & signs

This document uses the following symbols and signs:









Type	Symbol	Meaning
Safety alert DANGER		Indicates an imminent hazardous situation . If not avoided, it will result in death or serious injury .
WARNING		Indicates a potential hazardous situation . If not avoided, it can result in death or serious injury .
CAUTION		Indicates a probable hazardous situation or calls the attention to unsafe practices. If not avoided, it may result in injury .
Prohibited action	 (typical)	Indicates a dangerous action. Hence, you must not!
Mandatory action	 (typical)	Indicates a mandatory action. Hence, you must!
Requirement, Note, Remark		Indicates an activity you must perform prior to continuing, or gives information on a particular point that must be observed.
Best practice		Indicates an advice or recommendation on the easiest and best way to further proceed.
Material Damage		Indicates information particular to possible damage of the equipment.

Table 1-3 Symbols and signs

1.1.5 Trademarks and brand names

All trademarks, brand names or other signs mentioned in this manual remain the property of their respective owners. They are protected by trademark, copyright, and/or other applicable laws. For easier reading, no symbols such as ® or ™ are being used with respect to the trademarks or brand names mentioned herein.

Nothing in this manual shall be construed as granting any rights with respect to the mentioned trademarks, brand named or other signs, including without limitation neither the right to use the mentioned trademarks, brand names or other signs without permission of the respective owners.

The trademarks, brand names or other signs are mentioned in this manual solely for information or identification purposes.

1.1.6 Copyright

© 2026 maxon. All rights reserved. Any use, in particular reproduction, editing, translation, and copying, without prior written approval is not permitted (contact: maxon international ltd., Brünigstrasse 220, CH-6072 Sachseln, +41 41 666 15 00, www.maxongroup.com). Infringements will be prosecuted under civil and criminal law. The mentioned trademarks belong to their respective owners and are protected under trademark laws. Subject to change without prior notice.

CCMC | Safety Card User Manual | Edition 2026-05 | DocID rel13269

1.2 About the device

The «Safety Card» is an extension card for incorporation into suitable EPOS4 Positioning Controllers like the EPOS4 Module 60/20 or the EPOS4 Compact 60/20. It features an «STO» (Safe Torque Off) functionality for brushless DC motors according to DIN EN 61800-5-2 and an «Uncontrolled shutdown», Stop Category 0 according to IEC 60204-1



Find the latest edition of documentation and software here:

➔ www.maxongroup.com/en/drives-and-systems/controls/positioning-controllers

1.3 About the safety precautions

- Make sure that you have read and understood the note “READ THIS FIRST” on page A-2!
- Do not engage with any work unless you possess the stated skills (→Chapter “1.1.2 Target audience” on page 1-5)!
- Refer to →Chapter “1.1.4 Symbols & signs” on page 1-6 to understand the subsequently used indicators!
- You must observe any regulation applicable in the country and/or at the site of implementation with regard to health and safety/accident prevention and/or environmental protection!



DANGER

High voltage and/or electrical shock

Touching live wires causes death or serious injuries!

- Consider any power cable as connected to live power, unless having proven the opposite!
- Make sure that neither end of cable is connected to live power!
- Make sure that power source cannot be engaged while work is in process!
- Obey lock-out/tag-out procedures!
- Make sure to securely lock any power engaging equipment against unintentional engagement and tag it with your name!



Requirements

- Make sure that all associated devices and components are installed according to local regulations.
- Be aware that, by principle, an electronic apparatus cannot be considered fail-safe. Therefore, you must make sure that any machine/apparatus has been fitted with independent monitoring and safety equipment. If the machine/apparatus should break down, if it is operated incorrectly, if the control unit breaks down or if the cables break or get disconnected, etc., the complete drive system must return – and be kept – in a safe operating mode.
- Be aware that you are not entitled to perform any repair on components supplied by maxon.
- Maximum pollution degree: The system must operate in environments with a pollution degree not exceeding 2. Higher pollution levels can lead to conductive contamination and potential malfunctions and are only allowed with an appropriate housing providing IP54 protection rating.



Electrostatic sensitive device (ESD)

- Wear working cloth and use equipment in compliance with ESD Protective measures.
- Handle device with extra care.

**WARNING****Protection from direct contact**

- *Instruction: Install electrical components to prevent direct contact and avoid electric shock.*

Do not operate damaged equipment

- *Instruction: Check the equipment for damage. Do not operate damaged equipment until it is repaired or replaced by qualified personnel.*

Perform a visual inspection of the PDS(SR) before installation

- *Instruction: Inspect the PDS(SR) for visible damage or defects before installing it.*

Operate the PDS(SR) only in environments with a maximum pollution degree of 2

- *Instruction: Make sure that the PDS(SR) operates only in environments with a pollution degree of 2 or lower.*

Installation instruction for verifying correct connector pin assignment

- *Instruction: Follow the installation instructions and verify the correct connector pin assignment to prevent malfunctions.*

Verify configuration settings during commissioning by testing

- *Instruction: After configuring the system, perform a function test to verify that all settings are correct.*

Connectors must be connected or disconnected only when de-energized

- *Instruction: Before connecting or disconnecting electrical connectors, always ensure the equipment is de-energized to prevent injury or damage.*

Cleaning fluids can cause conductive contamination

- *Instruction: There is no cleaning foreseen, don't use any cleaning agents in order to avoid conductive contamination.*

Describe the procedure for troubleshooting

- *Instruction: Provide clear steps for troubleshooting to resolve issues efficiently and minimize downtime.*

Follow decommissioning instructions

- *Instruction: Follow the instructions for safely decommissioning the system to avoid damage or hazards.*

Taking system responsibility

- *Instruction: Please note that only the system integrator can take responsibility for the system and take the necessary measures.*

••page intentionally left blank••

2 SAFETY

2.1 Introduction

This chapter outlines the safety-related aspects and precautions necessary for the proper operation, maintenance, and integration of the Safety Card STO into EPOS4 Positioning Controllers for driving motors.

2.2 Main features

Article designation	Safety Card STO incorporated into EPOS4 Positioning Controllers <ul style="list-style-type: none"> EPOS4 Module 60/20 STO P/N 894249 EPOS4 Compact 60/20 CAN STO P/N 833726
Safety function	STO with dual-channel architecture , designed according to IEC 61800-5-2, for brushless DC motors only . Uncontrolled shutdown, Stop Category 0 according to IEC 60204-1. <div style="background-color: #ff9900; padding: 5px; margin-top: 10px;"> <p>⚠ WARNING</p> <ul style="list-style-type: none"> Use this safety function only with brushless DC motors. This safety sub-function can be used if power cut-off is required to prevent unexpected start-up in accordance with ISO 14118. In circumstances where there are external influences (e.g. falling suspended loads), further measures (e.g. mechanical brakes) may be required to prevent hazards. Electronic devices and certain contactors do not provide adequate protection against electric shock. If this function is activated, limited movement is still possible in the event of a failure in the power section of the PDS(SR). </div>
Safety level	Two-channel operation Up to SIL 3 according to IEC 61800-5-2 and PL e, Category 3 according to ISO 13849-1
Safety-related data	<ul style="list-style-type: none"> Safe Failure Fraction (SFF): 99 % Safety Function: Probability of dangerous failure per hour (PFH_d): 3.17×10^{-9} / h Diagnostic: Probability of dangerous failure per hour (PFH_d): 1260×10^{-9} / h Probability of dangerous failure on demand (PFD_{avg}): 2.93×10^{-4} Hardware Fault Tolerance (HFT): 1 (dual-channel) Mean Time to dangerous Failure (MTTF_d): <ul style="list-style-type: none"> - Per channel: 221.5 years - Total: 110.7 years Limited to 100 years according to ISO 13849 Diagnostic coverage (DC_{avg}): 92.6 % Reaction time: ≤ 10 ms OSSD tolerance: TP ≥ 20 ms / t_{off} ≤ 1 ms Mission time: 20 years
Hardware type	Type A
Current type	DC
Input type	Two independent, electrically isolated digital inputs
Output type	Two independent puls blockers on high-side and low-side gate signals
Response time	≤ 10 ms after STO request
Control type	n/a
Circuit type	n/a

Table 2-4 Main features

2.3 Control modes and reset

2.3.1 Operating states

By following these guidelines, integrators can ensure that the control modes and reset procedures are correctly implemented, providing clear and reliable operations for the SRP/CS system.

Operating state	Description	LED state indication	Motor control
Power down	This state indicates that the system is not powered correctly, overheated or defective.	all LEDs are off	Not possible – safe state
Error	This state indicates that the systems transition from «Power down» to «Ready to release» was not possible due to a wrong signal sequence or that a problem was detected in any other state or during a state transition (e.g. invalid signal states). This state can only be exited via a card reset if the error is resolved.	yellow LED D1 only	Not possible – safe state
Ready to release	This state indicates that the system is ready but the safety function is engaged.	yellow LED D1 green LED D2	Not possible – safe state
Released	This state indicates that the system is operational and the motor can be controlled.	green LED D2 only	This is the only state where motor control is possible.

Table 2-5 Operating states

2.3.2 Signal sequence and reset procedures

- In order to being able to change to «Ready to release» state, both STO input signals must be actively driven low to prevent unintentional immediate release, for example at a device startup or a card reset.



WARNING

If you configure the "Drive enable" function for a digital input, the controller checks the state of the input in cycles. If the safety function is in the "Released" state, the controller can immediately release the motor.

- The card requires a reset to exit the «Error» state and return to the «Ready to release» state. The reset is initiated by the EPOS4 Positioning Controller automatically at startup or after error clearance.
- Manual reset by a button or similar device is not intended. The reset command must be sent by the higherlevel control system.

3 SYSTEM OVERVIEW

3.1 Introduction

The Safety Card is an add-on card. You can only use it with EPOS4 Positioning Controllers that support this function. You can find all required information about the EPOS4 Positioning Controllers in the related product documentation. The following overview shows the structure of the documentation and how the different documents relate to each other:

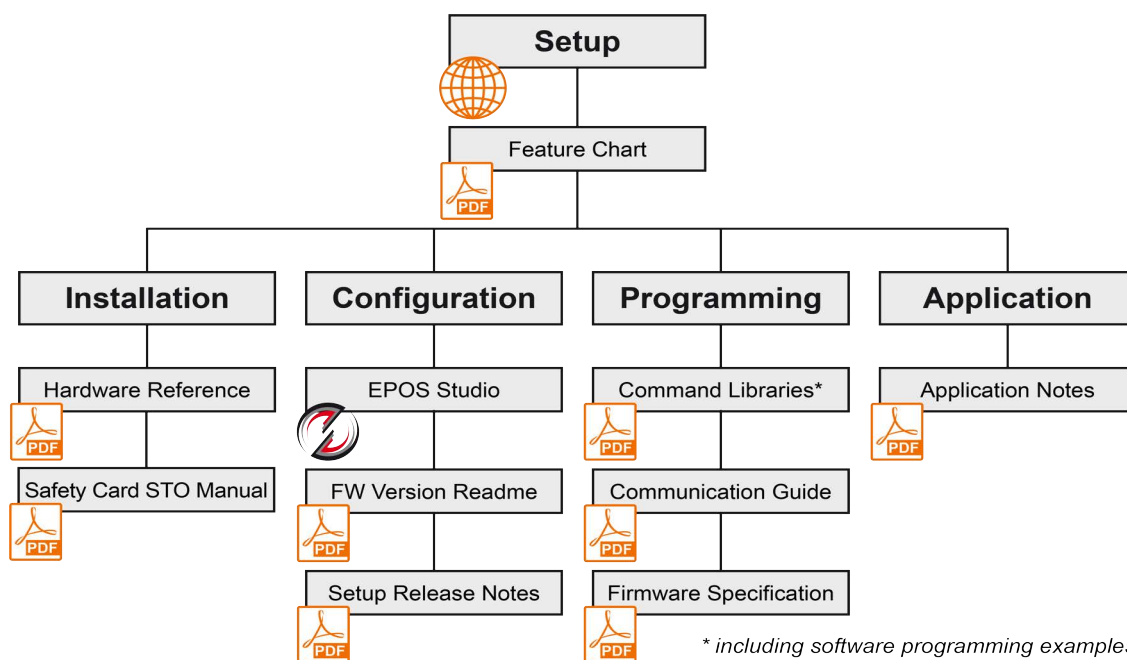

Figure 3-1 Documentation structure

3.2 Modularity and combinations

EPOS4 Positioning Controllers *EPOS4 Module 60/20 STO* and *EPOS4 Compact 60/20 CAN STO* are available products that include the Safety Card.

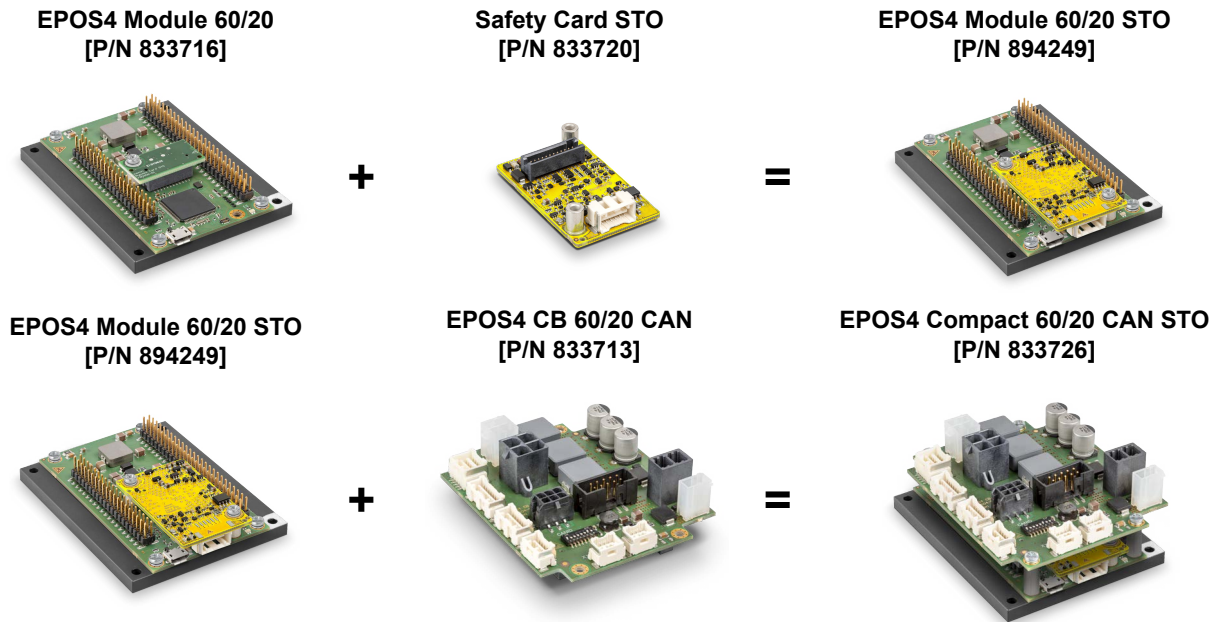

Figure 3-2 Modularity and combinations

However, you can combine the products yourself (for example, to retrofit a system). In this case, make sure that you mount and screw the Safety Card STO correctly as described in the related chapter.

4 SPECIFICATIONS

4.1 Technical data

Safety Card [P/N 833720]			
Inputs	STO Input 1...2		<ul style="list-style-type: none"> IEC 61131-2 type 1 digital inputs, galvanically isolated 60 VDC SELV/PELV (protection class III) voltage proof OSSD capable
	Status Indicators	State	yellow LED green LED → refer to Chapter "Table 5-8 LED indicators for safety circuit (STO status)" on page 5-21
Physical	Weight		approx. 9 g
	Dimensions (L × W × H)		45 × 28 × 10.35 mm
	IP protection level		IP00
	Mounting		mounting holes for M2.5 screws
	Vibration		The system can withstand sinusoidal vibrations of 1.5 mm @ 2 - 9 Hz and 5 m/s ² @ 9 - 200 Hz, 0.075 mm @ 10 - 57 Hz and 10 m/s ² @ 57 - 150 Hz. Shock response (Type I) is 50 m/s ² .
Environment	Temperature	Operation	-30 ... +103 °C [b]
		Storage	-40 ... +85 °C
	Humidity		5 % ... 95 % (condensation not permitted)
	Altitude		0 ... 5'000 m MSL

[a] Provided by the EPOS4 Positioning Controller

[b] If the PCB temperature exceeds the maximum, the Safety Card STO will change to «Error» state and STO is engaged

Table 4-6 Technical data

4.2 Dimensional drawing

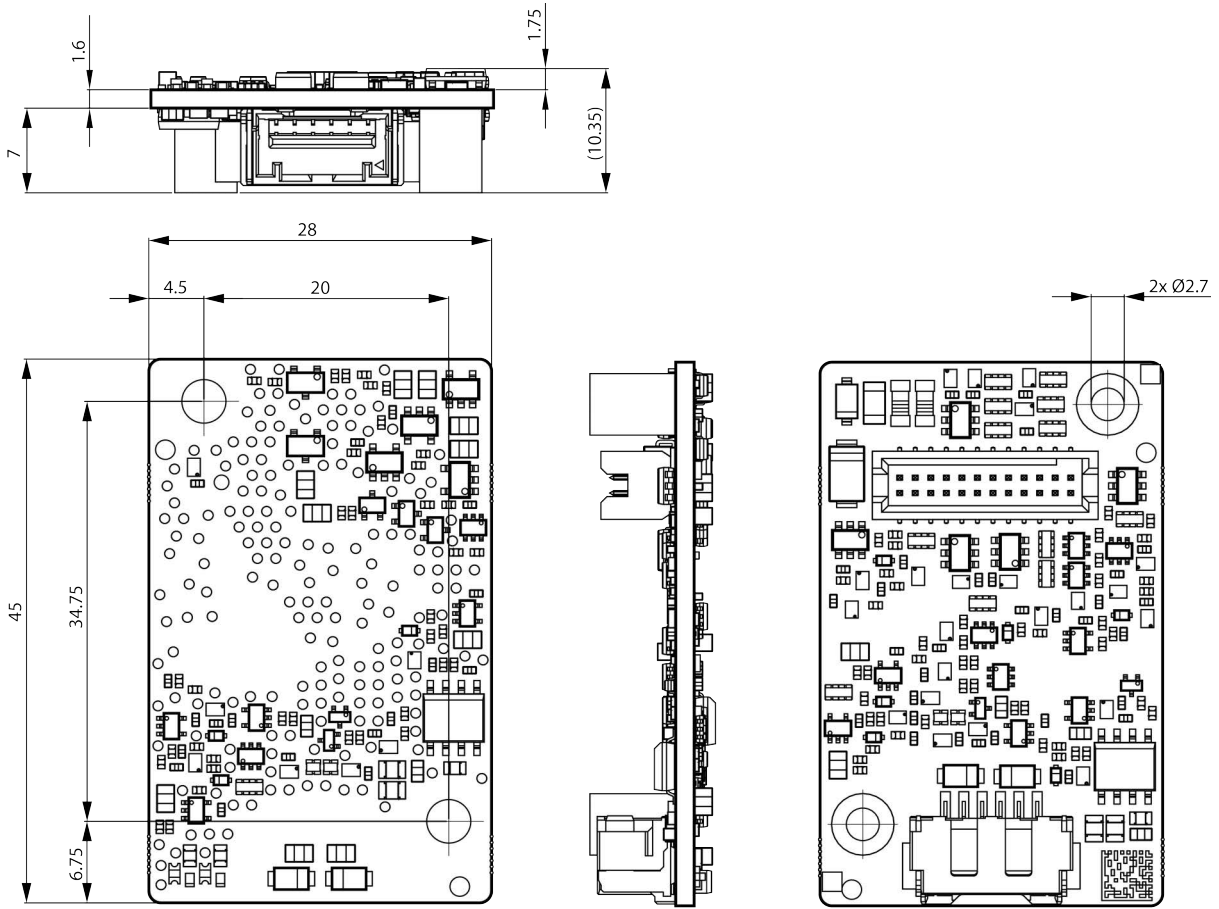

Figure 4-3 Safety Card – Dimensional drawing [mm]

4.3 Standards

The described device has been successfully tested for compliance with the below listed standards. Only the entire system, which is the fully functional equipment made up of all individual components, is able to be exposed to an EMC test. For interference-free operation, these components—such as the motor, servo controller, power supply unit, EMC filter, and cabling—are required.



Important notice

The device's compliance with the mentioned standards does not imply its compliance within the final, ready to operate setup. In order to achieve compliance of your operating system, you must perform EMC testing of the involved equipment as a whole.

Electromagnetic compatibility		
Generic	IEC/EN 61000-6-2	Immunity for industrial environments
	IEC/EN 61000-6-3	Emission standard for residential, commercial and light-industrial environments
Applied	IEC/EN 61000-4-2	Electrostatic discharge, restricted to connectors only (no housing) • 6 kV contact discharge or 8 kV air discharge
	IEC/EN 61000-4-3 IEC/EN 61000-6-7	Radiated, radio-frequency, electromagnetic field immunity test • 80 MHz to 1 GHz 20 V/m, 80% AM (1 kHz) • 1.4 GHz to 2.0 GHz 10 V/m, 80% AM (1 kHz) • 2.0 GHz bis 6.0 GHz 3 V/m, 80% AM (1 kHz)
	IEC/EN 61000-4-4	Electrical fast transient/burst immunity test • ± 2 kV (5/50 ns) 100 kHz
	IEC/EN 61000-4-6	Immunity to conducted disturbances, induced by radio-frequency fields • 0.15 MHz bis 80 MHz 20 V/m, 80% AM (1 kHz)
Others		
Environment	IEC/EN 60068-2-6	Environmental testing – Test Fc: Vibration (sinusoidal, 10...500 Hz, 20 m/s ²)
	MIL-STD-810F	Random transport (10...500 Hz up to 2.53 grms)
Safety	UL File Number	Unassembled printed circuit board E207844
	IEC/EN 61800-5-2	Adjustable speed electrical power drive systems - Part 5-2: Safety requirements - Functional
	EN ISO 13849-1	Safety of machinery - Safety-related parts of control systems - Part 1: General principles for design
	DIN EN ISO 12100	Safety of machinery - General principles for design - Risk assessment and risk reduction

Table 4-7 Standards

••page intentionally left blank••

5 SETUP

IMPORTANT NOTICE: PREREQUISITES FOR PERMISSION TO COMMENCE INSTALLATION

The **Safety Card** extension card is considered as partly completed machinery according to EU Directive 2006/42/EC, article 2, clause (c) and **is intended to be incorporated into or assembled with other machinery or other safety component or equipment.**



WARNING

Risk of injury

Operating the device without the full compliance of the surrounding system with the EU Directive 2006/42/EC may cause serious injuries!

- Do not operate the device, unless you have made completely sure that the other machinery fully complies with the EU directive's requirements!
- Do not operate the device, unless the other machinery fulfills all relevant health and safety aspects!
- Do not operate the device, unless all respective interfaces have been established and fulfill the requirements stated in this document!

5.1 Generally applicable rules



Safety first

- Check on the safety matters and rules (→refer to Chapter "1.3 About the safety precautions" on page 1-8) prior commencing with any activities.



Best practice

- Before initial operation, make sure that the motor can rotate freely. If the motor cannot rotate freely, disconnect it mechanically from the load.



Maximal permitted supply voltage

- Make sure that supply voltage of the EPOS4 Positioning Controller is 10 - 60 VDC.
- Wrong polarity will destroy the unit.



Avoid hot plugging

- Make sure that the power supply is switched off before plugging or unplugging any connectors.

5.2 Requirements for mechanical installation and commissioning

5.2.1 Required expertise



WARNING

Only qualified personnel are allowed to handle the product or system described in this document. Follow all documentation that applies to the task, especially the included safety and warning instructions. Qualified personnel are trained and experienced. They are able to identify risks and avoid hazards when working with this product or system.

The competent person must follow the manufacturer's instructions and national regulations during assembly and installation. Document and archive the installation and commissioning.

- Possible consequences of non-compliance:
Errors from lack of expertise during assembly and installation can cause malfunctions.
These malfunctions can lead to death or serious injury during installation, commissioning, or later operation.

5.3 Assembly instructions



You can purchase EPOS4 Positioning Controllers with STO functionality as a complete assembly that includes the Safety Card. However, you can also combine the products yourself (for example, to retrofit a system). In this case, make sure that you mount and screw the Safety Card STO correctly. Use two M2.5 × 14 screws with captive lock washers.

5.3.1 Visual inspection for damage



WARNING

Before you assemble the product, check the Safety Card for damage. Also check the transport packaging for damage.

- Do not operate a damaged device.
- Possible result if you do not obey this instruction:
Damage to the device can cause malfunctions. These malfunctions can create a hazardous situation.

5.4 Assembly process

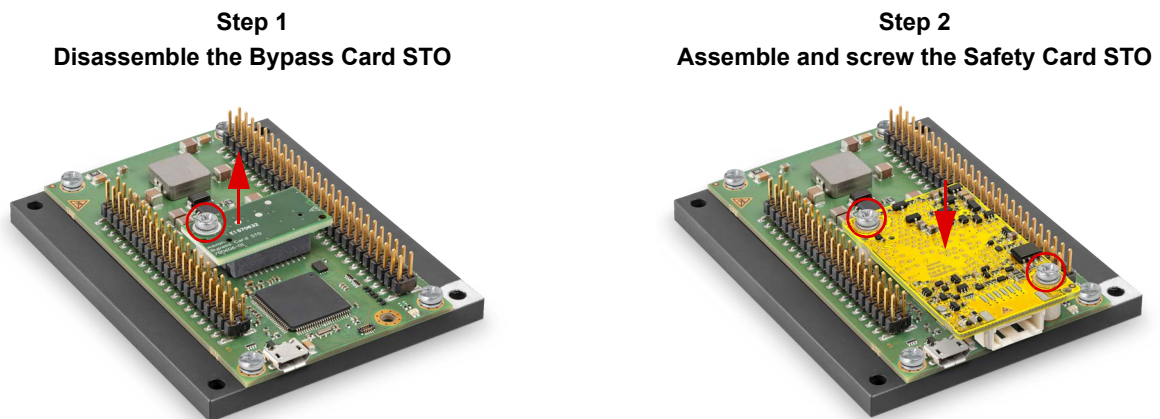

Figure 5-4 Assembly of Safety Card

5.4.1 Access restriction

To make sure that the safety function remains active, restrict access to the Safety Card. For example, lock the switch cabinet or install the system in a location that is not accessible.

5.5 Status indicators

The operating status of the safety function is shown by the two LEDs D1 and D2.

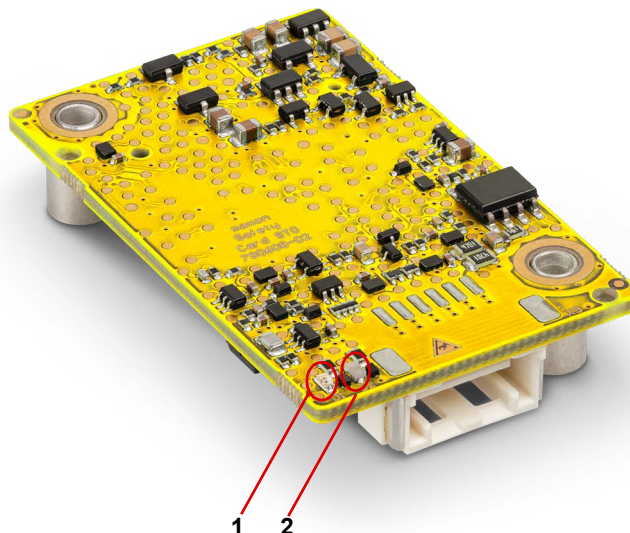

- 1 LED D1 (yellow) shows if the safety function is active. 2 LED D2 (green) shows that no error is present.

Figure 5-5 LED's – Location

State	D1		D2	
Power down	O	off	O	off
Error	●	yellow	O	off
Ready to release	●	yellow	●	green
Released	O	off	●	green

Table 5-8 LED indicators for safety circuit (STO status)

Description of LED behavior

- Power down**
 This state means that the system is not powered correctly, is overheated, or is defective. In this state, all LEDs are off. You cannot control the motor.
- Error**
 This state means that the system could not change from Power down to Ready to release because of an incorrect signal sequence. It can also mean that the system detected a problem in another state or during a state transition (for example, invalid signal states).
 In this state, LED D1 (yellow) is on, and LED D2 (green) is off. You cannot control the motor. To exit this state, you must reset the system.
For more information, refer to →Chapter “2.3.2 Signal sequence and reset procedures” on page 2-12
- Ready to release**
 This state is shown by LED D1 (yellow) and LED D2 (green) being on. It means that the system is ready, but the safety function is active. You cannot control the motor in this state.
- Released**
 This state is shown by LED D2 (green) being on and LED D1 (yellow) being off. It means that the safety function is not active and the system is operational. You can control the motor in this state. This is the only state where motor control is possible.

••page intentionally left blank••

6 CONNECTIONS



Safety first!

Check on the safety matters and rules (→Chapter “1.3 About the safety precautions” on page 1-8) prior commencing with any activities.



Safe cabling

- Cables must be shorter than 30 meters.
- Route safety-related signal lines separately from power lines.
- If the two STO input signals are not monitored for cross and short circuits, route them separately from each other. You can separate them by using shielding. The shield must fully enclose the cables and must be connected to functional earth. In this case, connect the EPOS4 Positioning Controller to functional earth.
- For single-channel use, connect the two STO input signals together:
Connect STO-IN1+ with STO-IN2+, and STO-IN1- with STO-IN2-.

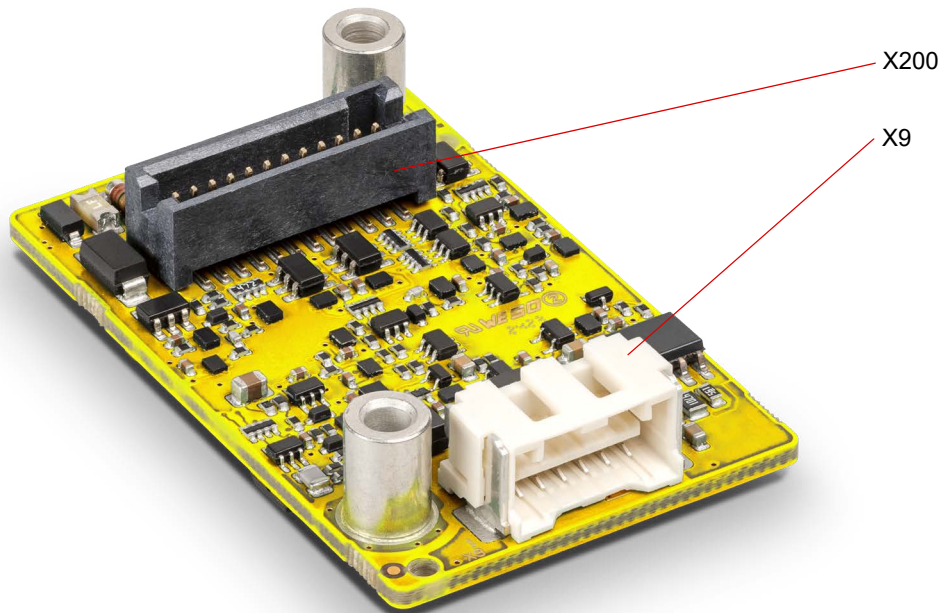

X200 Signal interface

X9 STO

Figure 6-6 Connections – Location

6.1 Signal interface (X200)

This board-to-board connector is the interface to the EPOS4 Positioning Controller. Do not manipulate or wire this connector.

The system sends feedback signals. These signals show the status of the STO function and the possibility to reset the Safety Card STO if necessary. The EPOS4 Positioning Controller monitors and processes these signals. You can check the status and reset the Safety Card STO through the available communication interfaces.

6.2 STO (X9)



Orientation of the connector

Depending on the product combination and mounting position, the plug may be upside down compared to the illustration below.

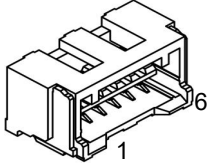

Figure 6-7 STO connector X9

Pin	Signal	Description
X9 1	STO-IN1+	Safe Torque Off input 1, positive signal
X9 2	STO-IN1-	Safe Torque Off input 1, negative signal
X9 3	Shield / Ground safety earth	Cable shield
X9 4	Shield / Ground safety earth	Cable shield
X9 5	STO-IN2-	Safe Torque Off input 2, negative signal
X9 6	STO-IN2+	Safe Torque Off input 2, positive signal

Table 6-9 STO connector (X9) – Pin assignment

Connector X9		
On board	Molex CLIK-Mate PCB Receptacle, Single Row, Surface Mount, Right-Angle, 6 circuit (5025850670)	
Plug	Housing	Molex CLIK-Mate, Single Row, 6 poles (5025780600)
	Contacts	Molex CLIK-Mate crimp terminals (502579)

Table 6-10 STO connector (X9) – specifications

Safe Torque Off inputs 1 ... 2	
Circuit type	IEC 61131-2 type 1 digital inputs, galvanically isolated
Input voltage	0...60 VDC
Max. input voltage	60 VDC SELV/PELV (protection class III) voltage proof (80 VDC transient)
Logic 0	<5 VDC
Logic 1	>15 VDC
Input current at logic 1	>2 mA @ 24 VDC typically 2.3 mA @ 24 VDC
Reaction time	<10 ms
OSSD tolerance	$T_P \geq 20 \text{ ms} / t_{\text{off}} \leq 1 \text{ ms}$

Table 6-11 STO inputs – specifications

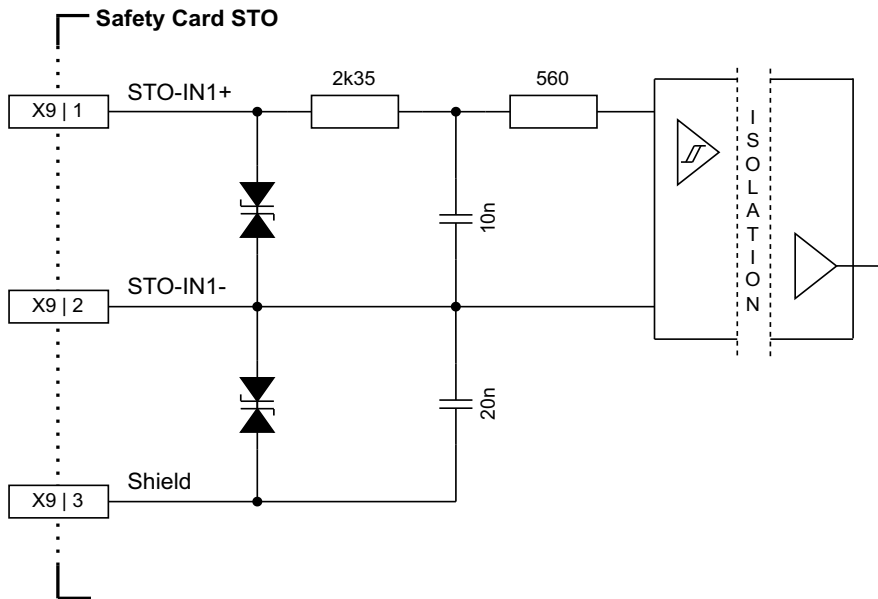

Figure 6-8 STO-IN1 simplified circuit (analogously valid for STO-IN2)

6.2.1 Dual-channel cabling

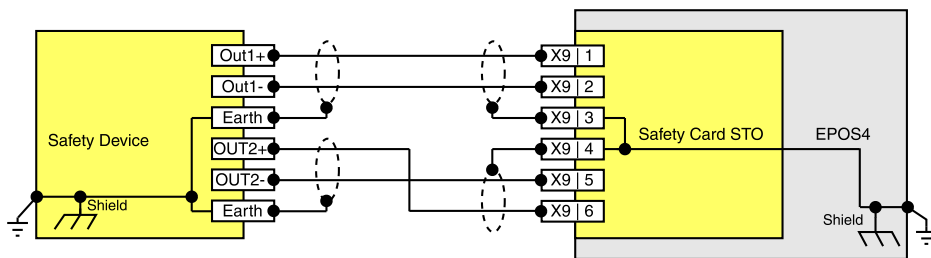

Figure 6-9 Dual-channel cabling configuration

6.2.2 Single-channel cabling

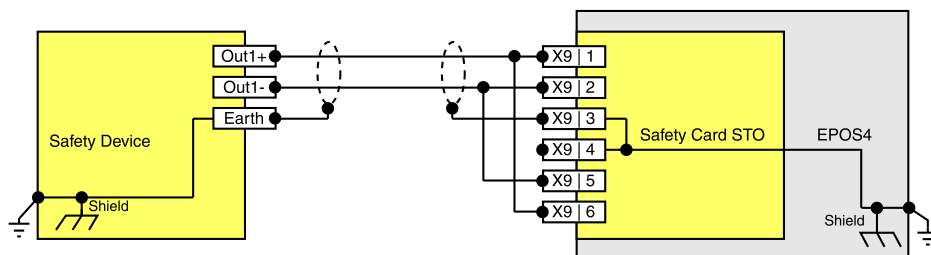

Figure 6-10 Single-channel cabling configuration

••page intentionally left blank••

7 MAINTENANCE AND PARTS

7.1 Maintenance procedures

7.1.1 Repair

If STO errors occur frequently, a qualified person must check the system and the power supply.

If a control unit experiences a malfunction, it must be taken out of operation immediately. Repairs on the device must not be performed; instead, the entire unit must be replaced to avoid any safety risks.

- **Revalidation**
Revalidation is not planned.
- **Cleaning**
There is no cleaning foreseen.
- **Maintenance of STO-relevant parts**
There are no parts in the STO-relevant section that require maintenance.
- **Field Failures**
Failures in the field must be fully analysed and reported back to maxon.

7.2 Easy and safe troubleshooting

Troubleshooting of STO systems

- **General issues and resolution**
 - a) **«Power down» state:** This state means that the system is not powered correctly, is overheated, or is defective. Possible causes include:
 - The EPOS4 Positioning Controller is not powered.
 - The Safety Card STO is not mounted correctly.
 - The system is overheated.Check the power supply and mounting of the Safety Card STO.
Let the system cool down.
If the problem remains, do not use the unit. Return it to the manufacturer.
 - b) **«Error» state:** This state means that the system could not change from power down to Ready to release because of an incorrect signal sequence.
It can also mean that the system detected a problem in another state or during a state transition (for example, incorrect voltage or temperature levels, or invalid signal states).
You can only exit this state by performing a reset after the error is resolved.
For the reset procedure, → refer to Chapter “2.3.2 Signal sequence and reset procedures” on page 2-12.
If the problem remains, do not use the unit. Return it to the manufacturer.
- **Specific notes**
 - a) **Error logging and documentation:** All errors encountered during the operation of the SRP/CS must be logged and documented as part of the maintenance records. This includes details of the error state, the actions taken to resolve the issue, and the outcome of those actions.
 - b) **Feedback mechanism:** The STO system provides feedback signals indicating its status to the application, which interacts with the higher-level control system. This mechanism helps in diagnosing issues and ensuring that the system responds appropriately to different states and errors.

7.3 Test intervals where relevant

Quarterly diagnostic test

Because the system cannot detect all internal component failures during operation, you must perform a power-up cycle every three months.

Annual functional testing

- **High-demand system requirement**
 - a) The safety function must be tested at least once a year to ensure its proper functioning. This annual test is critical for identifying any latent faults that might lead to a failure of the safety function.
 - b) If the system is installed in an environment where such testing is not expected (e.g., low-demand environments), a service technician must perform this test as part of a scheduled maintenance routine.
- **State monitoring**

Internal state monitoring of the system runs continuously, but formal verification through external testing is mandated annually. This ensures that all components function correctly and that any potential issues are identified and addressed promptly.

Detailed test procedures:

- **Power down tests:**

Make sure that the system correctly changes to the power down state when the internal supply voltage or temperature exceeds the allowed limits.
To do this, power down the EPOS4 Positioning Controller.
- **Error state test:**

Make sure that the system correctly changes to the Error state when you apply different signal states to the two STO inputs.
- **STO release and engage test**

Make sure that the system correctly changes from the Ready to release state to the Released state and back.
*To do this, apply a logic 1 signal to both STO inputs after power-up.
Then apply a logic 0 signal to both STO inputs.*

Documentation and logging:

- **Logbook requirements**

It is recommended to document each test cycle and any issues detected during the tests in a logbook. This documentation should include the details of the test procedures, results, and any corrective actions taken.

Maintenance integration:

- Ensure that these testing procedures are integrated into the regular maintenance schedule to maintain the safety and reliability of the SRP/CS system throughout its operational life.

By adhering to these guidelines, integrators and maintenance personnel can ensure that the SRP/CS system is regularly tested and maintained, thereby ensuring its safe and effective operation.

7.4 Life mission time

Mission time:

- **Usage restrictions:** 20 years, no limitation of the switch-on duration.

Consequences of exceeding mission time:

- **Replacement required:** If the maximum allowable mission time is exceeded, the control system must be replaced. Replacing individual components is not planned.
- **Safety risk:** Exceeding the mission time could result in a malfunction, leading to a hazardous condition.

DECLARATION OF CONFORMITY



EC Declaration of Conformity of the safety component according to EU Directive 2006/42/EC, Annex II 1A:

Manufacturer	maxon international ltd. Brünigstrasse 220 CH-6072 Sachseln
Authorized representative to compile the relevant technical documentation	maxon international ltd. Brünigstrasse 220 CH-6072 Sachseln
Product	Safety Card STO P/N 833720
Declaration of conformity	The manufacturer declares that the aforementioned product is considered a safety component and meets all the essential requirements of the EU Directive 2006/42/EC (Machinery Directive), the safety objectives of the Low Voltage Directive 2014/35/EU, the EMC Directive 2014/40/EU, and the RoHS Directive 2011/65/EU.
Notified body (name, address, identification number) and number of the EC typeexamination certificate as per Annex IX.	EC type approval was carried out and issued as certificate #097-003-25 by: CertX (CHE-487.868.652), Passage du Cardinal 5, 1700 Fribourg, Switzerland CertX is accredited by Swiss Accreditation Service (SAS) no. SCESp0129.
Harmonized standards applied:	<ul style="list-style-type: none"> • DIN EN ISO 12100:2010 Safety of machinery – General principles for design – Risk assessment and risk reduction • DIN EN ISO 13849:2023 Safety of machinery – Safety-related parts of control systems • DIN EN IEC 61800-3:2019 Adjustable speed electrical power drive systems – EMC requirements including specific test methods for drive systems and machine tools containing drive systems • DIN EN IEC 61800-5-1:2023 Adjustable speed electrical power drive systems – Safety requirements – Electrical, thermal and energy • DIN EN 61800-5-2:2017 Adjustable speed electrical power drive systems – Safety requirements – Functional
Reference to other technical standards and specifications used Further standards applied:	<ul style="list-style-type: none"> • SN EN 61508:2010 Functional safety of electrical/electronic/programmable electronic safety-related systems • DIN EN IEC 61800-2:2021 Adjustable speed electrical power drive systems – General requirements – Rating specifications for adjustable speed AC power drive systems
The specific technical documentation according to Annex VII Part A	The specific technical documentation has been prepared and will be made available to the national authorities upon request.

Sachseln, October 29th, 2025 on behalf of the manufacturer

Patrik Gnos
Chief Technical Officer CTO
maxon motor ag

Robert Fritsch
Corporate Functional Safety Manager
maxon international ltd.

••page intentionally left blank••

LIST OF FIGURES

Figure 3-1	Documentation structure	13
Figure 3-2	Modularity and combinations.	14
Figure 4-3	Safety Card – Dimensional drawing [mm].	16
Figure 5-4	Assembly of Safety Card.	20
Figure 5-5	LED's – Location.	21
Figure 6-6	Connections – Location.	23
Figure 6-7	STO connector X9.	24
Figure 6-8	STO-IN1 simplified circuit (analogously valid for STO-IN2)	25
Figure 6-9	Dual-channel cabling configuration	25
Figure 6-10	Single-channel cabling configuration.	25

LIST OF TABLES

Table 1-1	Notation used	5
Table 1-2	Abbreviations used	6
Table 1-3	Symbols and signs	6
Table 2-4	Main features	11
Table 2-5	Operating states	12
Table 4-6	Technical data	15
Table 4-7	Standards	17
Table 5-8	LED indicators for safety circuit (STO status).	21
Table 6-9	STO connector (X9) – Pin assignment	24
Table 6-10	STO connector (X9) – specifications	24
Table 6-11	STO inputs – specifications	24

INDEX

A

- alerts 6
 - CAUTION 6
 - DANGER 6
 - WARNING 6
- applicable EU directive 19
- applicable regulations 8

C

- country-specific regulations 8

D

- Declaration of conformity 29

E

- ESD 8
- EU directive, applicable 19

H

- how to
 - interpret icons (and signs) used in this document 6

I

- informatory signs 6

M

- mandatory action signs 6

N

- notations used 5

O

- operating license 19

P

- part numbers
 - 833713 14
 - 833716 14
 - 833720 14, 15, 29
 - 833726 11, 14
 - 894249 11, 14
- performance data 15
- precautions 8
- prerequisites prior installation 19
- prohibitive signs 6
- protective measures (ESD) 8
- purpose
 - of the device 7
 - of the document 5

R

- regulations, applicable 8

S

- safety alerts 6
- signs used 6
- standards, fulfilled 17

symbols used 6

T

technical data 15

