

EPOS4 Micro 24/5 EtherCAT EPOS4 Compact 24/5 EtherCAT 3-axes

Hardware Reference

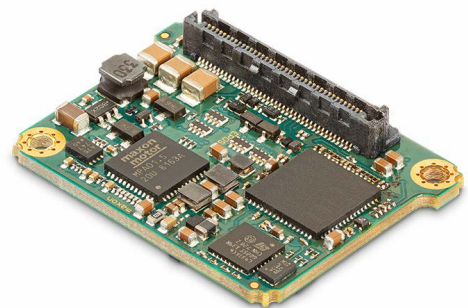
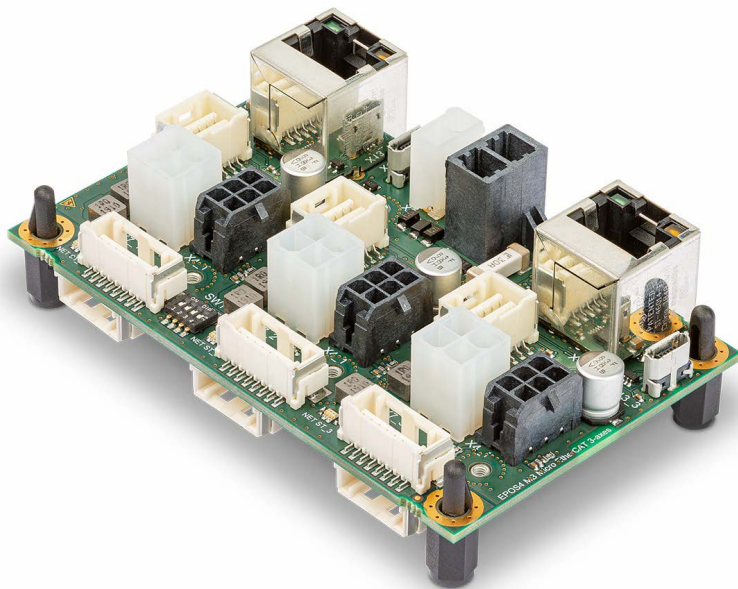

TABLE OF CONTENTS

1	ABOUT	5
1.1	About this Document.	5
1.2	About the Devices.	8
1.3	About the Safety Precautions	9
2	SPECIFICATIONS	11
2.1	Technical Data	11
2.2	Thermal Data	14
2.3	Limitations.	16
2.4	Dimensional Drawings	17
2.5	Standards	19
3	SETUP	21
3.1	Generally applicable Rules	21
3.2	Pin Assignment for Micro	22
3.3	Pin Assignment for Evaluation Board	24
3.3.1	EPOS4 EB Micro (638677)	24
3.3.2	Cabling	24
3.3.3	Tools	25
3.3.4	Connections	26
3.3.4.1	Power Supply (X1)	27
3.3.4.2	Logic Supply (X2)	27
3.3.4.3	Motor (X3).	28
3.3.4.4	Hall Sensor (X4)	29
3.3.4.5	Encoder (X5)	29
3.3.4.6	Sensor (X6)	30
3.3.4.7	Digital I/O (X7)	31

READ THIS FIRST

These instructions are intended for qualified technical personnel. Prior commencing with any activities...

- you must carefully read and understand this manual and
- you must follow the instructions given therein.

The EPOS4 Micro/Compact 24/5 EtherCAT positioning controller is considered as partly completed machinery according to EU Directive 2006/42/EC, Article 2, Clause (g) and is intended to be incorporated into or assembled with other machinery or other partly completed machinery or equipment.

Therefore, you must not put the device into service,...

- unless you have made completely sure that the other machinery fully complies with the EU directive's requirements!
- unless the other machinery fulfills all relevant health and safety aspects!
- unless all respective interfaces have been established and fulfill the herein stated requirements!

3.3.4.8	Analog I/O (X8)	31
3.3.4.9	USB (X13)	32
3.3.4.10	EtherCAT IN (X14) & EtherCAT OUT (X15)	33
3.3.5	Switch Configuration	34
3.3.5.1	DIP Switch SW1	34
3.3.5.2	Switch SW2	35
3.4	Pin Assignment for Motherboard and Compact	36
3.4.1	EPOS4 MB Micro EtherCAT 3-axes (659508)	36
3.4.2	EPOS4 Compact 24/5 EtherCAT 3-axes (684519)	36
3.4.3	Cabling	37
3.4.4	Tools	38
3.4.5	Connections	39
3.4.5.1	Power Supply (X1)	40
3.4.5.2	Logic Supply (X2)	40
3.4.5.3	Motor (X3_1 / X3_2 / X3_3)	41
3.4.5.4	Hall Sensor (X4_1 / X4_2 / X4_3)	42
3.4.5.5	Encoder/Sensor (X5/X6_1 / X5/X6_2 / X5/X6_3)	43
3.4.5.6	Digital I/O (X7_1 / X7_2 / X7_3)	44
3.4.5.7	Analog I/O (X8_1 / X8_2 / X8_3)	45
3.4.5.8	USB (X13_1 / X13_2 / X13_3)	46
3.4.5.9	EtherCAT IN (X14) & EtherCAT OUT (X15)	47
3.4.6	Switch Configuration	48
3.4.6.1	DIP Switch SW1	48
3.4.7	Axes Configuration on the Motherboard	49
3.5	Connection Specifications	50
3.5.1	Power Supply	50
3.5.2	Logic Supply	51
3.5.3	Motor	52
3.5.4	Hall Sensor	53
3.5.5	Encoder	54
3.5.6	Sensor	57
3.5.6.1	SSI Absolute Encoder	57
3.5.6.2	High-speed Digital I/Os	59
3.5.7	Digital I/Os	63
3.5.7.1	Digital Inputs Micro	63
3.5.7.2	Digital Inputs EvaBo & MoBo	64
3.5.7.3	Digital Outputs	66
3.5.8	Analog I/Os	68
3.5.9	USB	69
3.6	Prefab Cable Assemblies	70
3.7	Status Indicators	75
4	MOTHERBOARD DESIGN GUIDE	79
4.1	Requirements for Components of Third-party Suppliers	79
4.1.1	Terminal/Socket Combo Strip	79
4.1.2	Spacers	79

4.1.3	Supply Voltage	80
4.1.4	Logic Supply Voltage	81
4.1.5	Motor Cables and Motor Chokes	82
4.1.6	EIA RS422 Standard for High Speed I/Os and SSI Sensor	84
4.1.7	EtherCAT and Magnetics	84
4.1.8	LEDs	84
4.1.8.1	EtherCAT Status LEDs	85
4.1.8.2	EtherCAT Port LEDs	86
4.1.9	ESD Protection	87
4.1.10	Recommended Components and Manufacturers	88
4.2	Design Guidelines	90
4.2.1	Ground	90
4.2.2	Layout	90
4.3	Terminal/Socket Placement & SMT Footprint	91
5	WIRING	93
5.1	Possible Combinations to connect a Motor	96
5.2	Main Wiring Diagrams	98
5.3	Excerpts	100
	LIST OF FIGURES	105
	LIST OF TABLES	107
	INDEX	110

1 ABOUT

1.1 About this Document

1.1.1 Intended Purpose

Use the document to...

- stay safe,
- be fast,
- end up with set up and ready-to-go equipment.

The purpose of the present document is to familiarize you with the EPOS4 Micro/Compact 24/5 EtherCAT positioning controller and its matching evaluation board. It will highlight the tasks for safe and adequate installation and/or commissioning. Follow the described instructions ...

- to avoid dangerous situations,
- to keep installation and/or commissioning time at a minimum,
- to increase reliability and service life of the described equipment.

The present document is part of a documentation set and contains performance data and specifications, information on fulfilled standards, details on connections and pin assignment, and wiring examples. The below overview shows the documentation hierarchy and the interrelationship of its individual parts:

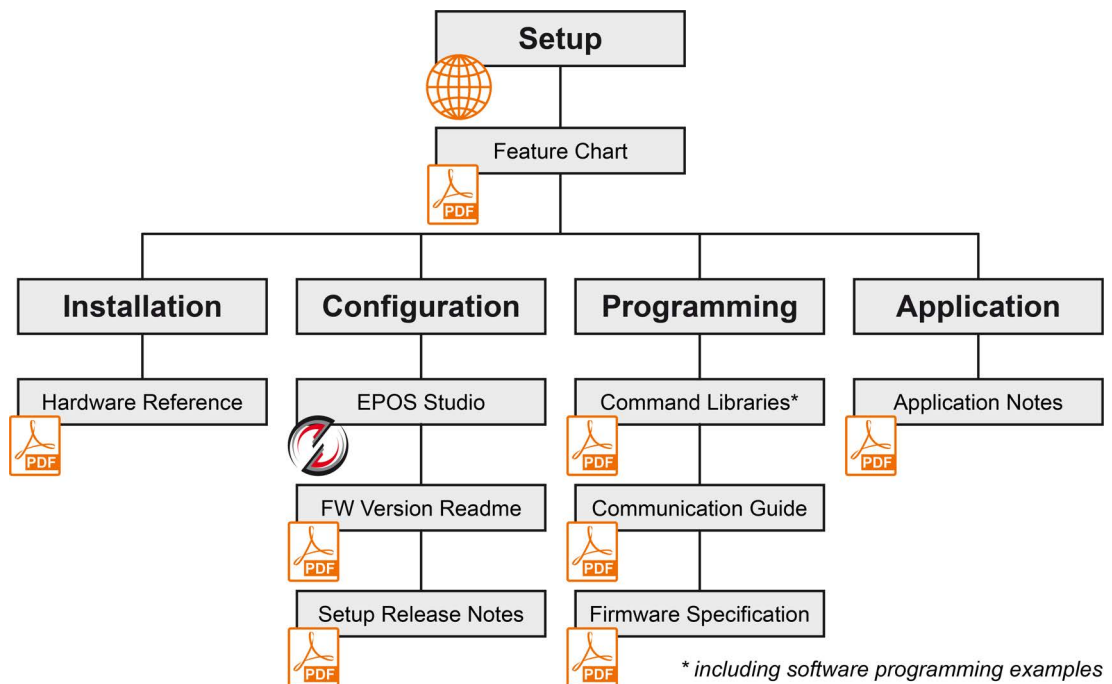

Figure 1-1 Documentation structure

1.1.2 Target Audience

The present document is intended for trained and skilled personnel. It conveys information on how to understand and fulfill the respective work and duties.

1.1.3 How to use

If not stated otherwise, the described details are valid for both the plug-in micro module and the evaluation board (→chapter “1.2 About the Devices” on page 1-8).

Throughout the document, the following notations and codes will be used.

Notation	Meaning
(n)	refers to an item (such as part numbers, list items, etc.)
→	denotes “see”, “see also”, “take note of” or “go to”

Table 1-1 Notation used

1.1.4 Symbols & Signs

In the course of the present document, the following symbols and signs will be used.







Type	Symbol	Meaning	
Safety alert	 (typical)	DANGER	Indicates an imminent hazardous situation . If not avoided, it will result in death or serious injury .
		WARNING	Indicates a potential hazardous situation . If not avoided, it can result in death or serious injury .
		CAUTION	Indicates a probable hazardous situation or calls the attention to unsafe practices. If not avoided, it may result in injury .
Prohibited action	 (typical)	Indicates a dangerous action. Hence, you must not!	
Mandatory action	 (typical)	Indicates a mandatory action. Hence, you must!	
Information		Requirement / Note / Remark	Indicates an activity you must perform prior continuing, or gives information on a particular item you need to observe.
		Best practice	Indicates an advice or recommendation on the easiest and best way to further proceed.
		Material Damage	Indicates information particular to possible damage of the equipment.

Table 1-2 Symbols and signs

1.1.5 Trademarks and Brand Names

For easier legibility, registered brand names are listed below and will not be further tagged with their respective trademark. It must be understood that the brands (the list below is not necessarily concluding) are protected by copyright and/or other intellectual property rights even if their legal trademarks are omitted in the later course of this document.

Brand name	Trademark owner
Adobe® Reader®	© Adobe Systems Incorporated, USA-San Jose, CA
CANopen® CiA®	© CiA CAN in Automation e.V, DE-Nuremberg
CLIK-Mate™ Micro-Fit™ Mini-Fit Jr.™ Mini-Fit Plus™ Mega-Fit®	© Molex, USA-Lisle, IL
EtherCAT®	© EtherCAT Technology Group, DE-Nuremberg, licensed by Beckhoff Automation GmbH, DE-Verl
Linux®	© Linus Torvalds (The Linux Foundation, USA-San Francisco CA)
Littelfuse®	© Littelfuse Inc., USA-Chicago, IL
Windows®	© Microsoft Corporation, USA-Redmond, WA

Table 1-3 Brand names and trademark owners

1.1.6 Copyright

© 2026 maxon. All rights reserved. Any use, in particular reproduction, editing, translation, and copying, without prior written approval is not permitted (contact: maxon international ltd., Brünigstrasse 220, CH-6072 Sachseln, +41 41 666 15 00, www.maxongroup.com). Infringements will be prosecuted under civil and criminal law. The mentioned trademarks belong to their respective owners and are protected under trademark laws. Subject to change without prior notice.

CCMC | EPOS4 Micro/Compact 24/5 EtherCAT Hardware Reference | Edition 2026-05 | DocID rel13655

1.2 About the Devices

Capabilities of the device, included features, and supported motors.

The EPOS4 Micro/Compact 24/5 EtherCAT is a miniaturized, full digital, smart positioning control unit. Its high power density allows flexible use for brushed DC and brushless EC (BLDC) motors up to approximately 120 Watts with various feedback options, such as Hall sensors, incremental encoders as well as absolute sensors in a multitude of drive applications.

The device is specially designed to be commanded and controlled as a slave node in an EtherCAT network. In addition, the unit can be operated via any USB communication port of a Windows or Linux workstation.

Latest technology, such as field-oriented control (FOC), acceleration/velocity feed forward, or dual loop, in combination with highest control cycle rates allow sophisticated, ease-of-use motion control.

The EPOS4 Micro/Compact 24/5 EtherCAT can be incorporated into customer-specific motherboards for single axis or multi axes motion control systems. For initial commissioning, the EPOS4 Micro/Compact 24/5 EtherCAT can be operated with the optionally available «EPOS4 EB Micro» evaluation board or «EPOS4 MB Micro EtherCAT» 3-axis motherboard. The controller is available in the following configurations:

- **EPOS4 Micro 24/5 EtherCAT (654731)**
Plug-in micro module for use with customer-specific motherboards
- **EPOS4 EB Micro (638677)**
Evaluation board for initial commissioning providing all connectors, including communication interfaces
- **EPOS4 MB Micro EtherCAT 3-axes (659508)**
3-axes motherboard to host three «EPOS4 Micro 24/5 EtherCAT», providing all connectors, including communication interfaces
- **EPOS4 Compact 24/5 EtherCAT 3-axes (684519)**
Fully integrated, compact, ready-to-use assembly comprising three micro modules and an EPOS4 MB Micro EtherCAT 3-axes motherboard

For easier legibility, in the later course of this document naming of components will be as follows:

Short form	Meaning
Compact	EPOS4 Compact 24/5 EtherCAT 3-axes
EPOS4	all controller versions as well as other EPOS4 positioning controllers as a whole
EvaBo	evaluation board EPOS4 EB Micro
Micro	EPOS4 Micro 24/5 EtherCAT
MoBo	motherboard EPOS4 MB Micro EtherCAT 3-axes

Table 1-4 Abbreviations



Find the latest edition of the present document as well as additional documentation and software for EPOS4 positioning controllers also on the Internet: →<http://epos.maxongroup.com>.

In addition, you may wish to browse the EPOS video library. It features video tutorials that provide easy to follow instructions on how to get started with «EPOS Studio» and shows you tips and tricks on how to setup communication interfaces, and so on. Explore on Vimeo: →<https://vimeo.com/album/4646388>

1.3 About the Safety Precautions

Keep in mind:

Safety first!
Always!

- Make sure that you have read and understood the note “READ THIS FIRST” on page A-2!
- Do not engage with any work unless you possess the stated skills (→chapter “1.1.2 Target Audience” on page 1-5)!
- Refer to →chapter “1.1.4 Symbols & Signs” on page 1-6 to understand the subsequently used indicators!
- You must observe any regulation applicable in the country and/or at the site of implementation with regard to health and safety/accident prevention and/or environmental protection!



DANGER

High voltage and/or electrical shock

Touching live wires causes death or serious injuries!

- Consider any power cable as connected to live power, unless having proven the opposite!
- Make sure that neither end of cable is connected to live power!
- Make sure that power source cannot be engaged while work is in process!
- Obey lock-out/tag-out procedures!
- Make sure to securely lock any power engaging equipment against unintentional engagement and tag it with your name!



Requirements

- Make sure that all associated devices and components are installed according to local regulations.
- Be aware that, by principle, an electronic apparatus can not be considered fail-safe. Therefore, you must make sure that any machine/apparatus has been fitted with independent monitoring and safety equipment. If the machine/apparatus should break down, if it is operated incorrectly, if the control unit breaks down or if the cables break or get disconnected, etc., the complete drive system must return – and be kept – in a safe operating mode.
- Be aware that you are not entitled to perform any repair on components supplied by maxon.



Electrostatic sensitive device (ESD)

- Wear working cloth and use equipment in compliance with ESD protective measures.
- Handle device with extra care.

••page intentionally left blank••

2 SPECIFICATIONS

2.1 Technical Data

EPOS4 Micro 24/5 EtherCAT (654731) EPOS4 EPOS4 EB Micro (638677) EPOS4 MB Micro EtherCAT 3-axes (659508) EPOS4 Compact 24/5 EtherCAT 3-axes (684519)			
Electrical Rating	Nominal power supply voltage +V _{CC}	10...24 VDC	
	Nominal logic supply voltage +V _C	Micro	10...24 VDC
		EvaBo	10...24 VDC, optional
		MoBo	
		Compact	
	Absolute supply voltage +V _{min} / +V _{max}	8 VDC / 28 VDC	
	Output voltage (max.)	0.9 x +V _{CC}	
	Output current I _{cont} / I _{max} (<10 s)	5 A / 15 A per axis	
	Pulse Width Modulation frequency	50 kHz	
	Sampling rate PI current controller	25 kHz (40 μs)	
	Sampling rate PI speed controller	2.5 kHz (400 μs)	
	Sampling rate PID positioning controller	2.5 kHz (400 μs)	
	Sampling rate analog input	2.5 kHz (400 μs)	
	Max. efficiency	97% (→Figure 2-4)	
	Max. speed DC motor	limited by max. permissible speed (motor) and max. output voltage (controller)	
	Max. speed EC motor (block)	100'000 rpm (1 pole pair)	
	Max. speed EC motor (sinusoidal)	50'000 rpm (1 pole pair)	
Built-in motor choke	Micro	—	
	EvaBo	3 x 15 μH; 5 A	
	MoBo	9 x 1 μH; 5 A	
	Compact	9 x 1 μH; 5 A	
Inputs & Outputs	Digital Input 1 (general purpose) Digital Input 2 (general purpose) Digital Input 3 (general purpose) Digital Input 4 (general purpose)	Micro	+2.1...+36 VDC
		EvaBo	DIP switch-selectable levels: • Logic: +2.0...+30 VDC • PLC: +9.0...+30 VDC
		MoBo	
		Compact	

Continued on next page.

EPOS4 Micro 24/5 EtherCAT (654731) EPOS4 EPOS4 EB Micro (638677) EPOS4 MB Micro EtherCAT 3-axes (659508) EPOS4 Compact 24/5 EtherCAT 3-axes (684519)			
Inputs & Outputs (continued)	Digital Output 1 (general purpose) Digital Output 2 (general purpose)	max. 36 VDC / $I_L \leq 500$ mA (open collector with internal pull-up)	
	Analog Input 1 Analog Input 2	Resolution 12-bit, $-10 \dots +10$ V, 10 kHz, differential	
	Analog Output 1	Resolution 12-bit, $-4 \dots +4$ V, 25 kHz, referenced to GND	
	Digital Hall sensor signals H1, H2, H3	$+2.0 \dots +24$ VDC (internal pull-up)	
	Digital incremental encoder signals A, A \setminus , B, B \setminus , I, I \setminus	EIA RS422, max. 6.25 MHz	
	Sensor signals (choice between multiple functions) • SSI absolute encoder (configurable, 0.4...2 MHz) • High-speed digital input 1 and High-speed digital output 1 (max. 6.25 MHz)	Micro EvaBo MoBo Compact	single-ended EIA RS422
Voltage Outputs	Sensor supply voltage V_{Sensor}	Micro	$+5$ VDC / $I_L \leq 145$ mA
		MoBo	$+5$ VDC / $I_L \leq 120$ mA per axis
		Compact	$+5$ VDC / $I_L \leq 120$ mA per axis
	Auxiliary output voltage V_{DD}	EvaBo	$+5$ VDC / $I_L \leq 300$ mA
Motor Connections	DC motor	+ Motor, – Motor	
	EC motor	Motor winding 1, Motor winding 2, Motor winding 3	
Interfaces	USB 2.0 / USB 3.0	Full Speed	
	EtherCAT	Full duplex (100 Mbit/s) as to IEE 802.3 100 Base Tx	
Status Indicators	Device status	Micro	Operation (green) / Error (red)
	NET status	Micro	RUN state (green) / Error (red)
		EvaBo	
		MoBo	
		Compact	
	NET port	EvaBo	Link activity (green)
MoBo			
Compact			

Continued on next page.

EPOS4 Micro 24/5 EtherCAT (654731) EPOS4 EPOS4 EB Micro (638677) EPOS4 MB Micro EtherCAT 3-axes (659508) EPOS4 Compact 24/5 EtherCAT 3-axes (684519)				
Physical	Weight	Micro	approx. 7 g	
		EvaBo	approx. 80 g	
		MoBo	approx. 65 g	
		Compact	approx. 85 g	
	Dimensions (L x W x H)	Micro	36.5 x 27.0 x 7.0 mm	
		EvaBo	100.0 x 90.0 x 22.5 mm	
		MoBo	90.0 x 56.0 x 29.1 mm	
		Compact	90.0 x 56.0 x 29.1 mm	
Mounting	Micro	mounting holes for M2 screws		
	EvaBo			
	MoBo	mounting holes Ø4 mm with mounted spacers		
	Compact			
Environment	Temperature	Operation	Micro: -30...+40 °C Compact: -30...+25 °C	
		Extended range [a]	Micro	+40...+60 °C Derating -0.25 A/°C (→Figure 2-2)
			Compact	+25...+50 °C Derating -0.2 A/°C (→Figure 2-3)
		Storage	-40...+85 °C	
	Altitude [b]	Operation	0...6'000 m MSL	
		Extended range [a]	6'000...10'000 m MSL Derating (→Figure 2-2 and Figure 2-3)	
	Humidity		5...90% (condensation not permitted)	

[a] Operation within the extended range (temperature and altitude) is permitted. However, a respective derating (declination of output current I_{cont}) as to the stated values will apply.

[b] Operating altitude in meters above Mean Sea Level, MSL.

Table 2-5 Technical data

2.2 Thermal Data

2.2.1 Derating of Output Current

MICRO



Thermal interconnection of the devices

The stated thermal data are measured with the «EPOS4 Micro/Compact 24/5 EtherCAT» mounted onto the evaluation board and attached with the respective screws. Thereby, the screws establish a thermal interconnection of the devices.

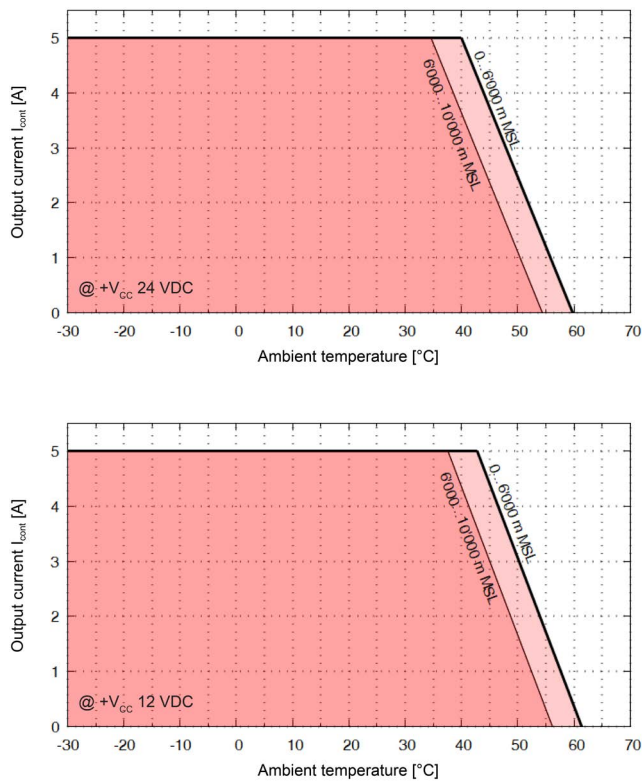

Figure 2-2 Derating of output current – Micro

COMPACT 3-AXIS



Thermal interconnection of the devices

The stated thermal data are measured with three «EPOS4 Micro 24/5 EtherCAT» mounted onto the motherboard and attached with the respective screws. Thereby, the screws establish a thermal interconnection of the devices.

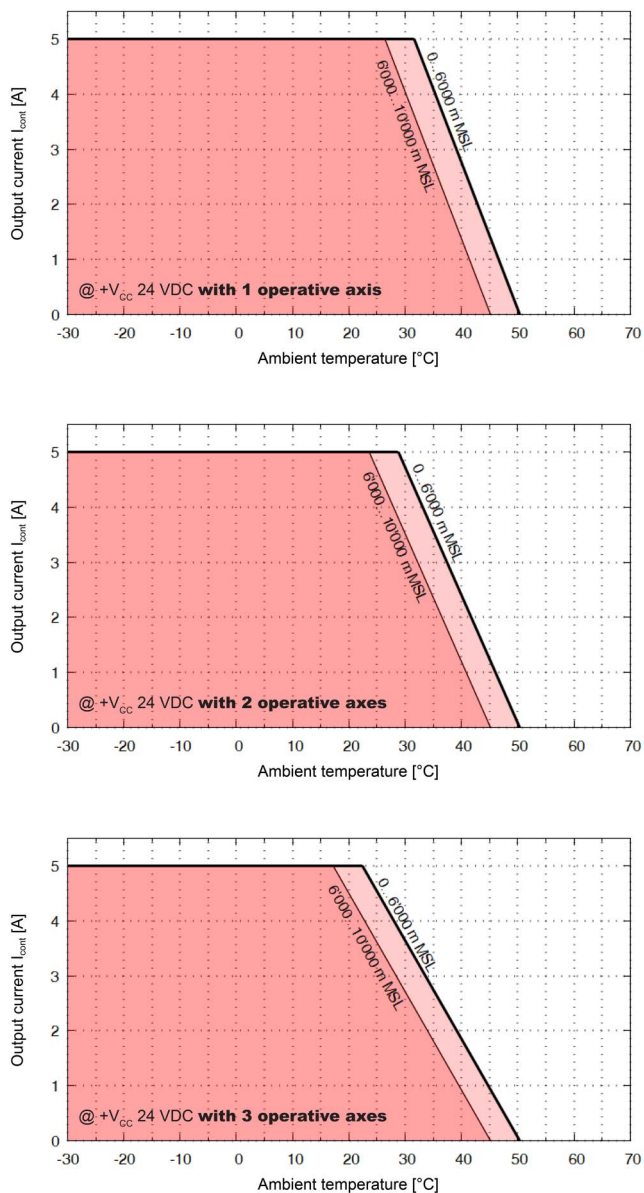

Figure 2-3 Derating of output current – Compact

2.2.2 Power Dissipation and Efficiency

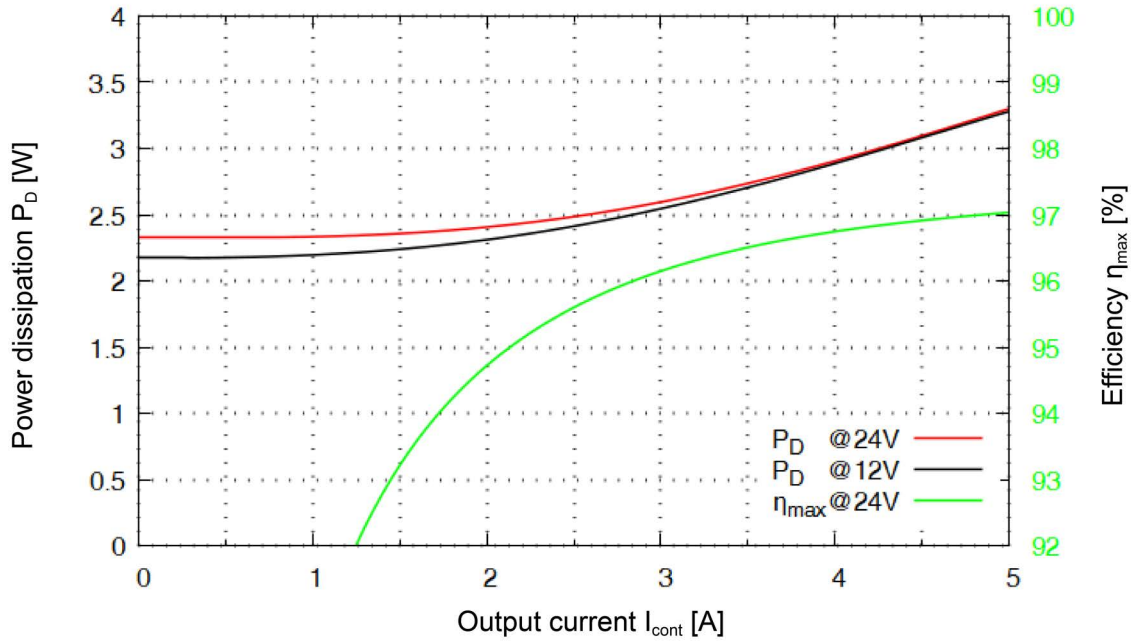

Figure 2-4 Power dissipation and efficiency – EPOS4 Micro 24/5 EtherCAT

2.3 Limitations

Protection functionality	Switch-off threshold	Recovery threshold
Undervoltage	7.0 V	7.5 V
Overvoltage	32 V	29 V
Overcurrent	20 A	—
Thermal overload	90 °C	85 °C

Table 2-6 Limitations

2.4 Dimensional Drawings

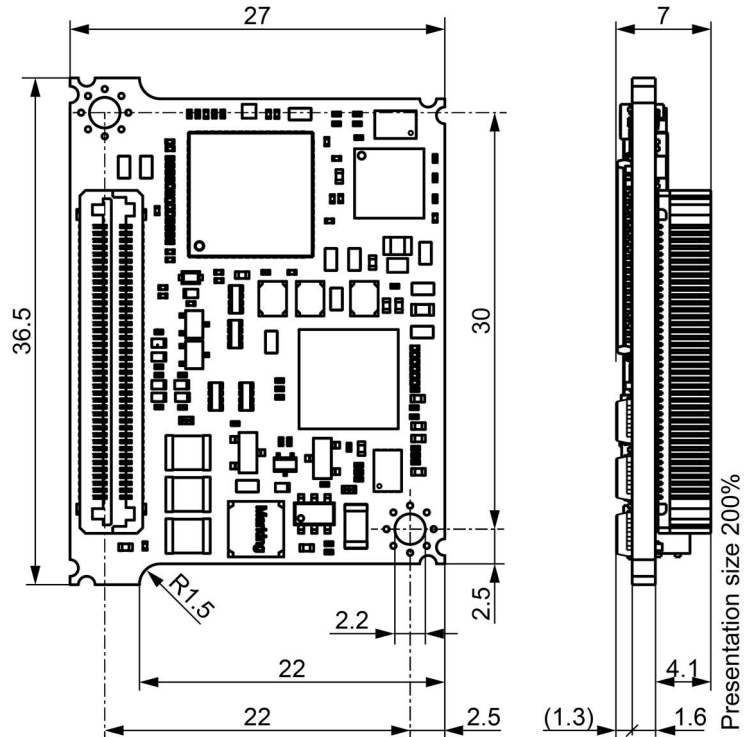

Figure 2-5 EPOS4 Micro 24/5 EtherCAT – Dimensional drawing [mm]

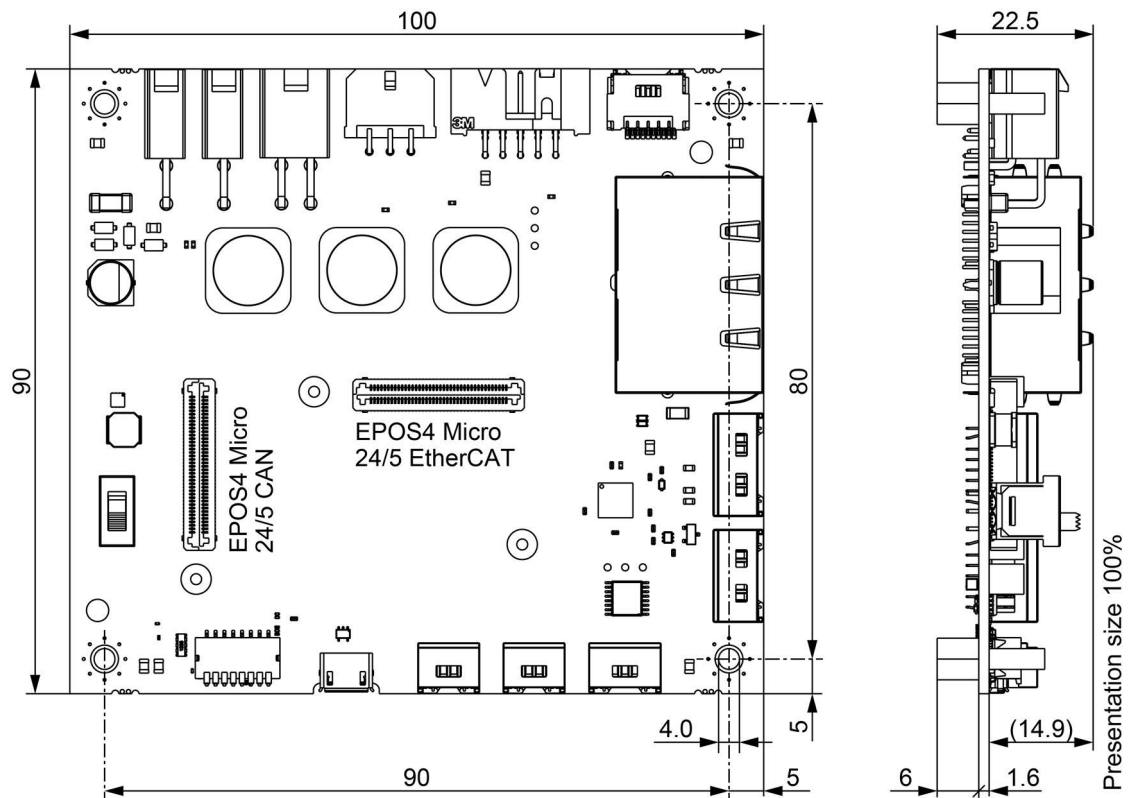

Figure 2-6 EPOS4 EB Micro – Dimensional drawing [mm]

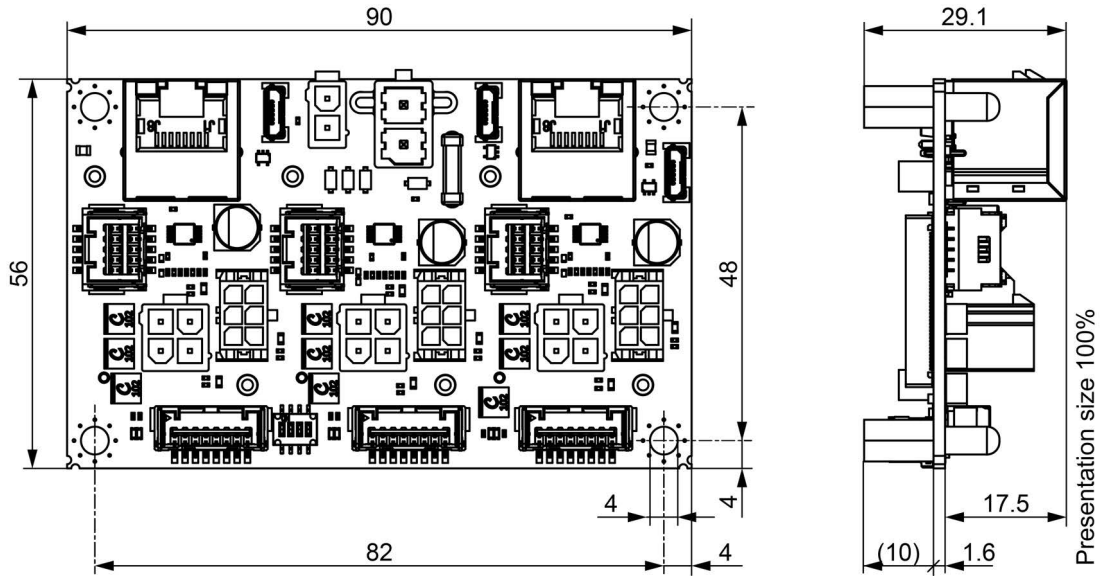

Figure 2-7 EPOS4 MB Micro EtherCAT 3-axes / EPOS4 Compact 24/5 EtherCAT 3-axes – Dimensional drawing [mm]

2.5 Standards

The described device has been successfully tested for compliance with the below listed standards. In practical terms, only the complete system (the fully operational equipment comprising all individual components, such as motor, servo controller, power supply unit, EMC filter, cabling etc.) can undergo an EMC test to ensure interference-free operation.



Important Notice

The device's compliance with the mentioned standards does not imply its compliance within the final, ready to operate setup. In order to achieve compliance of your operational system, you must perform EMC testing of the involved equipment as a whole.

Electromagnetic compatibility		
Generic	IEC/EN 61000-6-2	Immunity for industrial environments
	IEC/EN 61000-6-3	Emission standard for residential, commercial and light-industrial environments
Applied	IEC/EN 55032 (CISPR32)	Radio disturbance characteristics / radio interference
	IEC/EN 61000-4-3	Radiated, radio-frequency, electromagnetic field immunity test >10 V/m
	IEC/EN 61000-4-4	Electrical fast transient/burst immunity test ±2 kV (±1 kV with activated encoder index channel)
	IEC/EN 61000-4-6	Immunity to conducted disturbances, induced by radio-frequency fields 10 V _{rms}
Others		
Environment	IEC/EN 60068-2-6	Environmental testing – Test Fc: Vibration (sinusoidal, 10...500 Hz, 20 m/s ²)
	MIL-STD-810F	Random transport (10...500 Hz up to 2.53 g _{rms})
Safety	UL File Number	Unassembled printed circuit board <ul style="list-style-type: none"> • Micro: E207844 • EvaBo: E305654 • MoBo: E207844
Reliability	MIL-HDBK-217F	Reliability prediction of electronic equipment Environment: Ground, benign (GB) Ambient temperature: 298 K (25 °C) Component stress: In accordance with circuit diagram and nominal power Mean Time Between Failures (MTBF) <ul style="list-style-type: none"> • Micro: 638'102 hours • MoBo: 465'901 hours • Compact: 146'032 hours

Table 2-7 Standards

••page intentionally left blank••

3 SETUP

IMPORTANT NOTICE: PREREQUISITES FOR PERMISSION TO COMMENCE INSTALLATION

The EPOS4 Micro/Compact 24/5 EtherCAT positioning controller is considered as partly completed machinery according to EU Directive 2006/42/EC, Article 2, Clause (g) and **is intended to be incorporated into or assembled with other machinery or other partly completed machinery or equipment.**



WARNING

Risk of injury

Operating the device without the full compliance of the surrounding system with the EU Directive 2006/42/EC may cause serious injuries!

- Do not operate the device, unless you have made completely sure that the other machinery fully complies with the EU directive's requirements!
- Do not operate the device, unless the other machinery fulfills all relevant health and safety aspects!
- Do not operate the device, unless all respective interfaces have been established and fulfill the requirements stated in this document!

3.1 Generally applicable Rules



Maximal permitted supply voltage

- Make sure that supply power is between 10...24 VDC.
- Supply voltages above 28 VDC, or wrong polarity will destroy the unit.
- Note that the necessary output current is depending on the load torque. Yet, the output current limits are as follows:
 - continuous max. 5 A
 - short-time (acceleration) max. 15 A



Hot plugging the USB interface may cause hardware damage

If the USB interface is being hot-plugged (connecting while the power supply is on), the possibly high potential differences of the two power supplies of controller and PC/Notebook can lead to damaged hardware.

- Avoid potential differences between the power supply of controller and PC/Notebook or, if possible, balance them.
- Insert the USB connector first, then switch on the power supply of the controller.

3.2 Pin Assignment for Micro

For in-depth details on connections → chapter “3.5 Connection Specifications” on page 3-50.

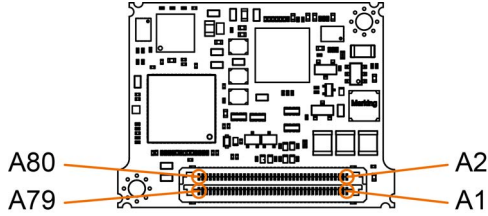

Figure 3-8 Pin assignment

Pin	Signal	Description
A1...A6**	Motor (+M)	DC motor: Motor +
	Motor winding 1	EC motor: Winding 1
A7...A12**	Motor (-M)	DC motor: Motor -
	Motor winding 2	EC motor: Winding 2
A13...A18**	Motor winding 3	EC motor: Winding 3
A19...A24**	+V _{CC}	Power supply voltage (+10...+24 VDC)
A25	GND	Ground
A26	+V _C	Logic supply voltage (+10...+24 VDC)
A27...A32**	GND	Ground
A33	Hall sensor 1	Hall sensor 1 input
A34	Channel A	Digital incremental encoder channel A
A35	Hall sensor 2	Hall sensor 2 input
A36	Channel A\	Digital incremental encoder channel A complement
A37	Hall sensor 3	Hall sensor 3 input
A38	Channel B	Digital incremental encoder channel B
A39	V _{Sensor}	Sensor supply voltage (+5 VDC; I _L ≤145 mA)
A40	Channel B\	Digital incremental encoder channel B complement
A41	DigIN1	Digital input 1
A42	Channel I	Digital incremental encoder channel I
A43	DigIN2	Digital input 2
A44	Channel I\	Digital incremental encoder channel I complement
A45	DigIN3	Digital input 3
A46	AnIN1+	Analog input 1, positive signal
A47	DigIN4	Digital input 4
A48	AnIN1-	Analog input 1, negative signal
A49	DigOUT1	Digital output 1
A50	AnIN2+	Analog input 2, positive signal
A51	DigOUT2	Digital output 2
A52	AnIN2-	Analog input 2, negative signal
A53	Data	Data (SSI)
	HsDigIN4	High-speed digital input 4

Continued on next page.

Pin	Signal	Description
A54	AnOUT1	Analog output 1
A55	Clock	Clock (SSI)
	HsDigOUT1	High-speed digital output 1
A56	LinkModeIN	EtherCAT link mode IN
A57...A58	GND	Ground
A59	USB_D-	USB Data-
A60	V _{Bus}	USB bus supply voltage input +5 VDC
A61	USB_D+	USB Data+
A62	LinkModeOUT	EtherCAT link mode OUT
A63...A64	GND	Ground
A65	TX+IN	Transmission Data+ IN
A66	TX+OUT	Transmission Data+ OUT
A67	TX-IN	Transmission Data- IN
A68	TX-OUT	Transmission Data- OUT
A69	CTIN	Transmission Receive Center Tap IN
A70	CTOUT	Transmission Receive Center Tap OUT
A71	RX+IN	Receive Data+ IN
A72	RX+OUT	Receive Data+ OUT
A73	RX-IN	Receive Data- IN
A74	RX-OUT	Receive Data- OUT
A75...A76	GND	Ground
A77	NET LED IN	Link activity LED NET port IN
A78	NET LED OUT	Link activity LED NET port OUT
A79	NET state RUN	NET state run (green LED)
A80	NET state ERROR	NET state error (red LED)
** Connect all pins in respect to the individual pin current rating.		

Table 3-8 Pin assignment A1...A80

3.3 Pin Assignment for Evaluation Board

For easy initial commissioning, a ready-made evaluation board is available to connect with the Micro. It comprises all required connections.

For in-depth details on connections → chapter “3.5 Connection Specifications” on page 3-50.

3.3.1 EPOS4 EB Micro (638677)

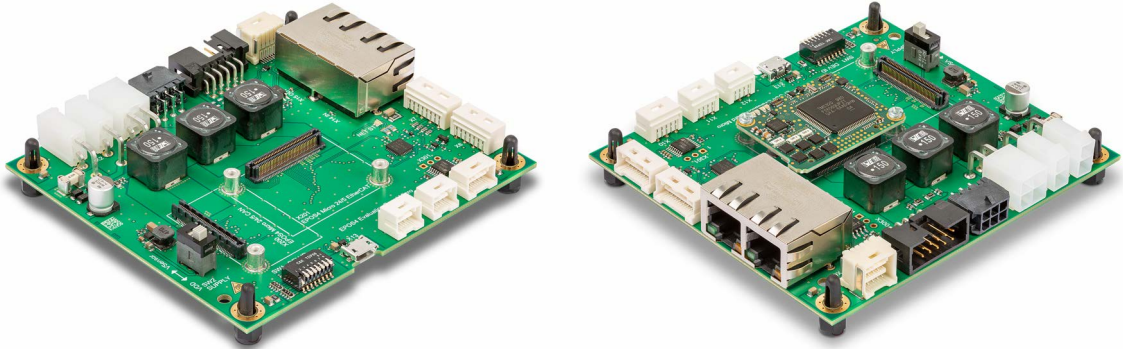

Figure 3-9 EPOS4 EB Micro (without/with EPOS4 Micro 24/5 EtherCAT)

3.3.2 Cabling

PLUG&PLAY

Take advantage of maxon’s prefab cable assemblies. They come as ready-to-use parts and will help to reduce commissioning time to a minimum.

- a) Check the following table and find the part number of the cable assembly that matches the setup you will be using.
- b) Follow the cross-reference to get the cable’s pin assignment.

Connector EvaBo	Prefab Cable Assembly		
	Designation	Part Number	→Page
X1	Power Cable	275829	3-70
X2	Power Cable	275829	3-70
X3	Motor Cable	275851	3-70
X4	Hall Sensor Cable	275878	3-71
X5	Encoder Cable	275934	3-71
X6	Sensor Cable 5x2core	520852	3-71
X7	Signal Cable 8core	520853	3-73
X8	Signal Cable 7core	520854	3-73
X13	USB Type A - micro B Cable	403968	3-74
X14	Ethernet Cable	422827	3-74
X15	Ethernet Cable	422827	3-74

Table 3-9 Prefab maxon cables

MAKE&BAKE YOUR OWN

If you decide not to employ maxon’s prefab cable assemblies, you might wish to use the prepackaged kit that contains all connectors required to make up your own cabling.

EPOS4 Connector Set (520859)		
Connector	Specification	Quantity
Connectors		
—	Molex Mega-Fit, 2 poles (171692-0102)	1
X1 / X2	Molex Mini-Fit Jr., 2 poles (39-01-2020)	2
X3	Molex Mini-Fit Jr., 4 poles (39-01-2040)	1
—	Molex Mega-Fit, 4 poles (171692-0104)	1
X4	Molex Micro-Fit 3.0, 6 poles (430-25-0600)	1
X6	Molex CLIK-Mate, dual row, 10 poles (503149-1000)	1
X7	Molex CLIK-Mate, single row, 8 poles (502578-0800)	2
X8	Molex CLIK-Mate, single row, 7 poles (502578-0700)	1
—	Molex CLIK-Mate, single row, 5 poles (502578-0500)	1
—	Molex CLIK-Mate, single row, 4 poles (502578-0400)	2
Crimp Terminals		
—	Molex Mega-Fit, female crimp terminal (172063-0311)	7
X1 / X2 / X3	Molex Mini-Fit Plus crimp terminal (45750-1111)	9
X4	Molex Micro-Fit 3.0 female crimp terminal (43030-0010)	7
X6...X12	Molex CLIK-Mate crimp terminal (502579-0100)	45
Accessories		
X5	3M Retainer Clip with strain relief, height 13.5 mm (3505-8110)	1

Table 3-10 EPOS4 Connector Set – Content

3.3.3 Tools

Tool	Manufacturer	Part Number
Hand crimper for CLIK-Mate crimp terminals	Molex	63819-4600
Hand crimper for Micro-Fit 3.0 crimp terminals	Molex	63819-0000
Hand crimper for Mini-Fit crimp terminals	Molex	63819-0900

Table 3-11 Recommended tools

3.3.4 Connections

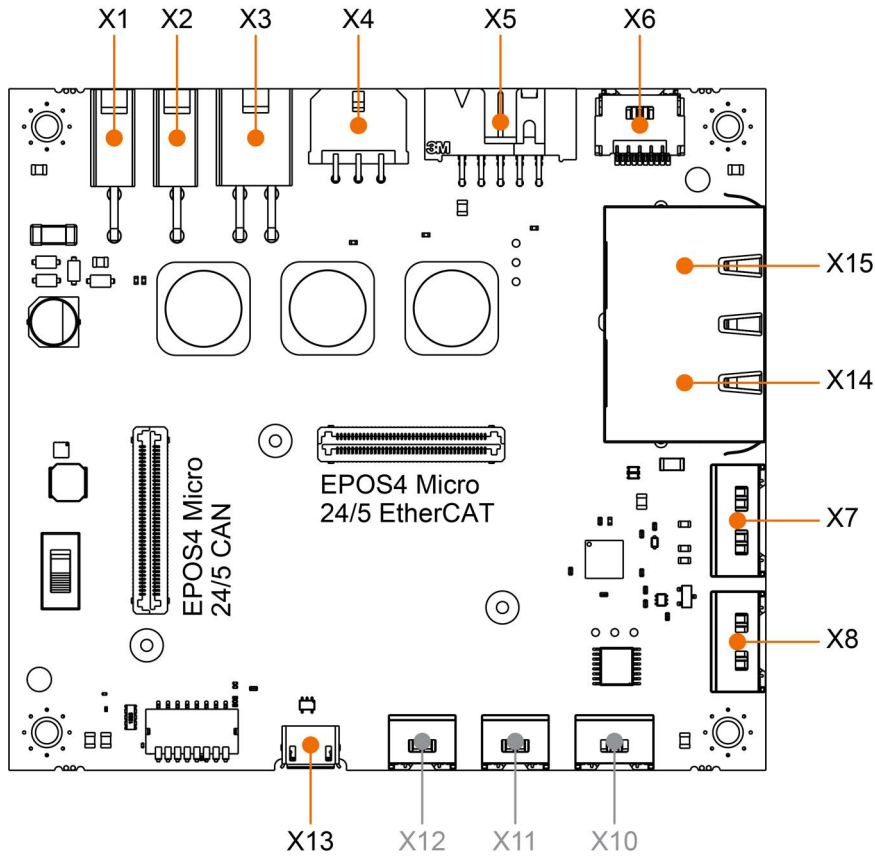

X1	Power Supply →page 3-27	X8	Analog I/O →page 3-31
X2	Logic Supply →page 3-27	X10	RS232 [c]
X3	Motor →page 3-28	X11	CAN 1 [c]
X4	Hall Sensor →page 3-29	X12	CAN 1 [c]
X5	Encoder →page 3-29	X13	USB →page 3-32
X6	Sensor →page 3-30	X14	EtherCAT IN →page 3-33
X7	Digital I/O →page 3-31	X15	EtherCAT OUT →page 3-33

[c] Only available with EPOS4 Micro 24/5 CAN

Figure 3-10 Connector Boards – Connectors



How to read pin assignment tables

- The first column describes both the pin number of the connector and of the matching prefab maxon cable's Head A.
- The second column describes the cable core color of the prefab maxon cable.
- The third column describes the pin number of the prefab maxon cable's Head B.
- For the matching prefab cable see →Table 3-9.

3.3.4.1 Power Supply (X1)



Best practice

Keep the motor mechanically disconnected during the setup and adjustment phase.

For the matching ready-made cable see →“Power Cable (275829)” on page 3-70.

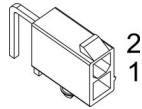

Figure 3-11 Power supply connector X1

X1 Head A Pin	Prefab Cable Color	Head B Pin	Signal	Description
1	black	-	GND	Ground
2	black	+	+V _{CC}	Power supply voltage (+10...+24 VDC)

Table 3-12 Power supply connector X1 – Pin assignment

3.3.4.2 Logic Supply (X2)



Separate power supply

The logic part of the controller may be supplied by separate supply voltage

- *Micro*: The logic supply must be connected separately.
- *EvaBo*: If not supplied separately, the logic supply is internally connected to the power supply.

For the matching ready-made cable see →“Power Cable (275829)” on page 3-70.

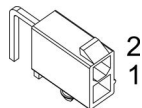

Figure 3-12 Logic supply connector X2

X2 Head A Pin	Prefab Cable Color	Head B Pin	Signal	Description
1	black	-	GND	Ground
2	black	+	+V _C	Logic supply voltage (+10...+24 VDC)

Table 3-13 Logic supply connector X2 – Pin assignment

3.3.4.3 Motor (X3)

The controller is set to drive either maxon EC motor (BLDC, brushless DC motor) or maxon DC motor (brushed DC motor) with separated motor/encoder cable.

For the matching ready-made cable see →“Motor Cable (275851)” on page 3-70.

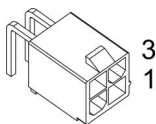

Figure 3-13 Motor connectors X3

X3 Head A Pin	Prefab Cable Color	Head B Pin	Signal	Description
1	white		Motor (+M)	DC motor: Motor +
2	brown		Motor (-M)	DC motor: Motor -
3	green		—	not connected
4	black		Motor shield	Cable shield

Table 3-14 Motor connector X3 – Pin assignment for maxon DC motor

X3 Head A Pin	Prefab Cable Color	Head B Pin	Signal	Description
1	white		Motor winding 1	EC motor: Winding 1
2	brown		Motor winding 2	EC motor: Winding 2
3	green		Motor winding 3	EC motor: Winding 3
4	black		Motor shield	Cable shield

Table 3-15 Motor connector X3 – Pin assignment for maxon EC motor

3.3.4.4 Hall Sensor (X4)

For the matching ready-made cable see →“Hall Sensor Cable (275878)” on page 3-70.

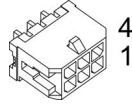

Figure 3-14 Hall sensor connector X4

X4 Head A Pin	Prefab Cable Color	Head B Pin	Signal	Description
1	green		Hall sensor 1	Hall sensor 1 input
2	brown		Hall sensor 2	Hall sensor 2 input
3	white		Hall sensor 3	Hall sensor 3 input
4	yellow		GND	Ground
5	grey		V_{Sensor}	Sensor supply voltage (+5 VDC; $I_L \leq 145 \text{ mA}$)
6	black		Hall shield	Cable shield

Table 3-16 Hall sensor connector X4 – Pin assignment

3.3.4.5 Encoder (X5)

For the matching ready-made cable see →“Encoder Cable (275934)” on page 3-71.

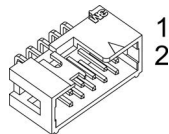

Figure 3-15 Encoder connector X5

X5 Head A Pin	Prefab Cable Color	Head B Pin	Signal	Description
1	brown	1	—	not connected
2	white	2	V_{Sensor}	Sensor supply voltage (+5 VDC; $I_L \leq 145 \text{ mA}$)
3	red	3	GND	Ground
4	white	4	—	not connected
5	orange	5	Channel A\	Channel A complement
6	white	6	Channel A	Channel A
7	yellow	7	Channel B\	Channel B complement
8	white	8	Channel B	Channel B
9	green	9	Channel I\	Channel I complement
10	white	10	Channel I	Channel I

Table 3-17 Encoder connector X5 – Pin assignment

Continued on next page.

Accessories		
Suitable strain relief	Retainer	For sockets with strain relief: 1 retainer clip, height 13.5 mm, 3M (3505-8110)
		For sockets without strain relief: 1 retainer clip, height 7.9 mm, 3M (3505-8010)
	Latch	For sockets with strain relief: 2 pieces, 3M (3505-33B)

Table 3-18 Encoder connector X5 – Accessories

3.3.4.6 Sensor (X6)

For the matching ready-made cable see →“Sensor Cable 5x2core (520852)” on page 3-71.

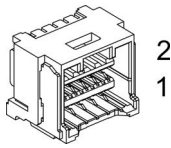

Figure 3-16 Sensor connector X6

X6 Head A Pin	Prefab Cable Color	Head B Pin	Signal	Description
1	white	1	—	not connected
2	brown	2	—	not connected
3	green	3	—	not connected
4	yellow	4	—	not connected
5	grey	5	Clock	Clock (SSI)
			HsDigOUT1	High-speed digital output 1
6	pink	6	Clock\	Clock (SSI) complement
			HsDigOUT1\	High-speed digital output 1 complement
7	blue	7	Data	Data (SSI)
			HsDigIN4	High-speed digital input 4
8	red	8	Data\	Data (SSI) complement
			HsDigIN4\	High-speed digital Input 4 complement
9	black	9	GND	Ground
10 [d]	violet	10	V_{Sensor}	Sensor output voltage (+5 VDC; $I_L \leq 145 \text{ mA}$)
			V_{DD}	Auxiliary output voltage (+5 VDC; $I_L \leq 300 \text{ mA}$)

[d] switchable between V_{Sensor} and V_{DD} using switch SW2 on the EvaBo

Table 3-19 Sensor connector X6 – Pin assignment

3.3.4.7 Digital I/O (X7)

For the matching ready-made cable see →“Signal Cable 8core (520853)” on page 3-73.

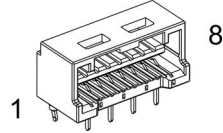

Figure 3-17 Digital I/O connector X7

X7 Head A Pin	Prefab Cable Color	Head B Pin	Signal	Description
1	white	1	DigIN1	Digital input 1
2	brown	2	DigIN2	Digital input 2
3	green	3	DigIN3	Digital input 3
4	yellow	4	DigIN4	Digital input 4
5	grey	5	DigOUT1	Digital output 1
6	pink	6	DigOUT2	Digital output 2
7	blue	7	GND	Ground
8 [d]	red	8	V_{Sensor}	Sensor supply voltage (+5 VDC; $I_L \leq 145 \text{ mA}$)
			V_{DD}	Auxiliary output voltage (+5 VDC; $I_L \leq 300 \text{ mA}$)

[d] switchable between V_{Sensor} and V_{DD} using switch SW2 on the EvaBo

Table 3-20 Digital I/O connector X7 – Pin assignment

3.3.4.8 Analog I/O (X8)

For the matching ready-made cable see →“Signal Cable 7core (520854)” on page 3-73.

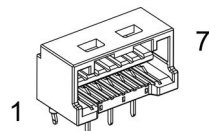

Figure 3-18 Analog I/O connector X8

X8 Head A Pin	Prefab Cable Color	Head B Pin	Signal	Description
1	white	1	AnIN1+	Analog input 1, positive signal
2	brown	2	AnIN1-	Analog input 1, negative signal
3	green	3	AnIN2+	Analog input 2, positive signal
4	yellow	4	AnIN2-	Analog input 2, negative signal
5	grey	5	AnOUT1	Analog output 1
6	pink	6	—	not connected
7	blue	7	GND	Ground

Table 3-21 Analog I/O connector X8 – Pin assignment

3.3.4.9 USB (X13)

For the matching ready-made cable see →“USB Type A - micro B Cable (403968)” on page 3-74.



Hot plugging the USB interface may cause hardware damage

If the USB interface is being hot-plugged (connecting while the power supply is on), the possibly high potential differences of the two power supplies of controller and PC/Notebook can lead to damaged hardware.

- *Avoid potential differences between the power supply of controller and PC/Notebook or, if possible, balance them.*
- *Insert the USB connector first, then switch on the power supply of the controller.*

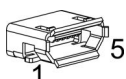

Figure 3-19 USB connector X13

Micro Header Pin	EvaBo Connector Pin	PC's USB Terminal	Signal	Description
A58	X13 5	4	GND	USB ground
A59	X13 2	2	USB_D-	USB Data- (twisted pair with Data+)
A60	X13 1	1	V _{BUS}	USB bus supply voltage input +5 VDC
A61	X13 3	3	USB_D+	USB Data+ (twisted pair with Data-)
—	X13 4	—	ID	not connected

Table 3-22 USB connector X13 – Pin assignment

3.3.4.10 EtherCAT IN (X14) & EtherCAT OUT (X15)

For the matching ready-made cable see →“Ethernet Cable (422827)” on page 3-74.



Wrong plugging may cause hardware damage

Even though both EtherCAT sockets are prepared for identical external wiring, make sure to always connect them as follows.

- Use only standard Cat5 cables with RJ45 plug, such as maxon’s «Ethernet Cable» (422827).
- Use EtherCAT IN (X14) as «Input».
- Use EtherCAT OUT (X15) as «Output».

For detailed information see separate document →«EPOS4 Communication Guide».

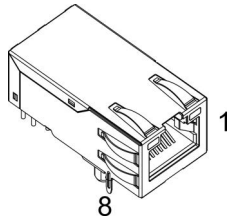

Figure 3-20 EtherCAT IN connector X14 & EtherCAT OUT connectorX15

X14 X15 Head A Pin	Prefab Cable Color	Head B Pin	Signal	Description
1	white/ orange	1	TX+	Transmission Data+
2	orange	2	TX-	Transmission Data-
3	white/ green	3	RX+	Receive Data+
4	blue	4	–	not applicable
5	white/ blue	5	–	not applicable
6	green	6	RX-	Receive Data-
7	white/ brown	7	–	not applicable
8	brown	8	–	not applicable

Table 3-23 EtherCAT IN connector X14 & EtherCAT OUT connectorX15 – Pin assignment

3.3.5 Switch Configuration

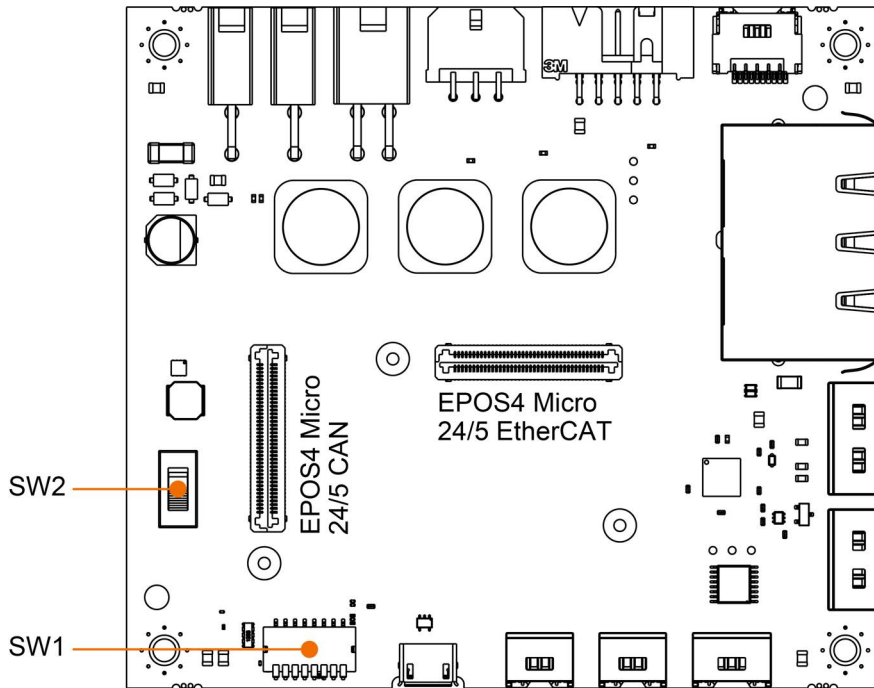

Figure 3-21 EvaBo switches – Location

3.3.5.1 DIP Switch SW1



Non-functional switches 1...7

Switches 1...7 of DIP switch SW1 are only operative in combination with EPOS4 Micro 24/5 CAN.

DIGITAL INPUT LEVEL

For details → chapter “3.5.7 Digital I/Os” on page 3-63.

Switch	OFF	ON
8	<p>↑ OFF ↓ ON</p> <p>Logic level (factory setting)</p>	<p>↑ OFF ↓ ON</p> <p>PLC level</p>

Table 3-24 EvaBo DIP switch SW1 – Digital input level

3.3.5.2 Switch SW2

Using switch SW2, you may select the source of the voltage supply for peripherals and related transceivers. This allows you to check whether the Sensor supply voltage V_{Sensor} provided by the Micro is sufficient for your use application or if you will need to provide an additional voltage source.

Connector		Position “VDD”	Position “VSensor”
		Supply source	
Hall sensor	X4	Sensor supply voltage V_{Sensor}	Sensor supply voltage V_{Sensor}
Encoder	X5	Sensor supply voltage V_{Sensor}	Sensor supply voltage V_{Sensor}
Sensor	X6	Output voltage V_{DD}	Sensor supply voltage V_{Sensor}
Digital I/Os	X7	Output voltage V_{DD}	Sensor supply voltage V_{Sensor}

Table 3-25 Voltage outputs – Source

Voltage outputs	
Sensor supply voltage V_{Sensor}	+5 VDC; $I_L \leq 145$ mA; sourced by Micro
Auxiliary supply voltage V_{DD}	+5 VDC; $I_L \leq 300$ mA, sourced by EvaBo

Table 3-26 Voltage outputs – Specifications

3.4 Pin Assignment for Motherboard and Compact

For compact multi-axis system solutions, a ready-made 3-axes motherboard is available. It comprises all required interfaces to connect with up to three Micros. The ready-to-use Compact hosts three Micros and is fully equipped to act as a 3-axis slave controller.

For in-depth details on the connections see →chapter “3.5 Connection Specifications” on page 3-50. For an overview on the matching ready-made cables see →chapter “3.4.3 Cabling” on page 3-37.

3.4.1 EPOS4 MB Micro EtherCAT 3-axes (659508)

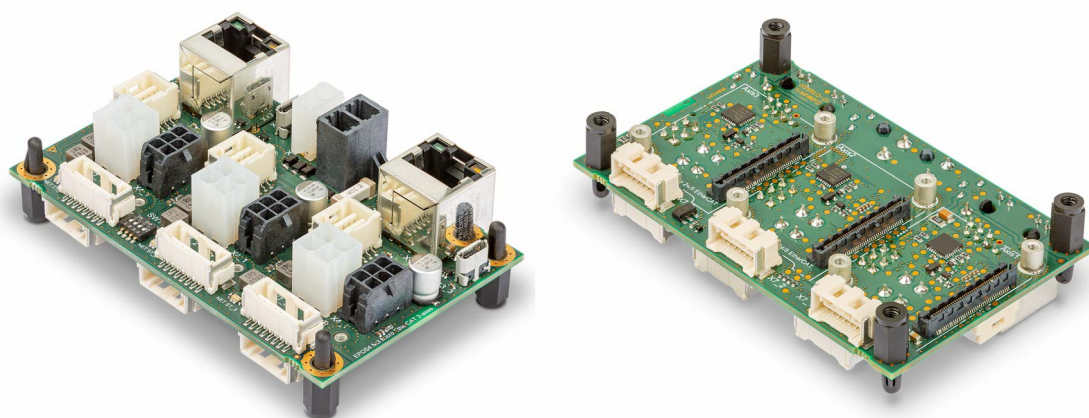

Figure 3-22 EPOS4 MB Micro EtherCAT 3-axes (top view/bottom view)

3.4.2 EPOS4 Compact 24/5 EtherCAT 3-axes (684519)

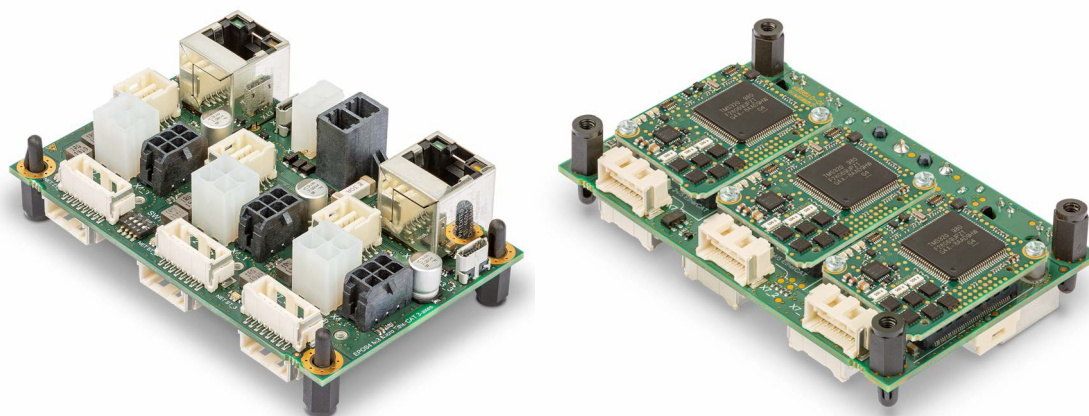

Figure 3-23 EPOS4 Compact 24/5 EtherCAT 3-axes (top view/bottom view)

3.4.3 Cabling

PLUG&PLAY

Take advantage of maxon's prefab cable assemblies. They come as ready-to-use parts and will help to reduce commissioning time to a minimum.

- a) Check the following table and find the part number of the cable assembly that matches the setup you will be using.
- b) Follow the cross-reference to get the cable's pin assignment.

Connector MoBo & Compact	Prefab Cable Assembly		
	Designation	Part Number	→Page
X1	Power Cable High Current	520850	3-70
X2	Power Cable	275829	3-70
X3_1 X3_2 X3_3	Motor Cable	275851	3-70
X4_1 X4_2 X4_3	Hall Sensor Cable	275878	3-71
X5/X6_1 X5/X6_2 X5/X6_3	Sensor Cable 5x2core Adapter Cable Encoder CLIK-Mate to DIN41651	520852 693573	3-71 3-72
X7_1 X7_2 X7_3	Signal Cable 8core	520853	3-73
X8_1 X8_2 X8_3	Signal Cable 7core	520854	3-73
X13_1 X13_2 X13_3	USB Type A - micro B Cable	403968	3-74
X14	Ethernet Cable	422827	3-74
X15	Ethernet Cable	422827	3-74

Table 3-27 Prefab maxon cables

MAKE&BAKE YOUR OWN

If you decide not to employ maxon's prefab cable assemblies, you might wish to use the prepackaged kit that contains all connectors required to make up your own cabling.

EPOS4 MB Micro EtherCAT 3-axes Connector Set (691408)		
Connector	Specification	Quantity
Connectors		
X1	Molex Mega-Fit, 2 poles (171692-0102)	1
X2	Molex Mini-Fit Jr., 2 poles (39-01-2020)	1
X3_1 X3_2 X3_3	Molex Mini-Fit Jr., 4 poles (39-01-2040)	3
X4_1 X4_2 X4_3	Molex Micro-Fit 3.0, 6 poles (43025-0600)	3
X6_1 X6_2 X6_3	Molex CLIK-Mate, dual row, 10 poles (503149-1000)	3
X7_1 X7_2 X7_3	Molex CLIK-Mate, single row, 8 poles (502578-0800)	3
X8_1 X8_2 X8_3	Molex CLIK-Mate, single row, 7 poles (502578-0700)	3
Crimp Terminals		
X1	Molex Mega-Fit female crimp terminal (172063-0311)	3
X2 / X3	Molex Mini-Fit Plus female crimp terminal (45750-1111)	15
X4	Molex Micro-Fit 3.0 female crimp terminal (43030-0010)	19
X6 / X7 / X8	Molex CLIK-Mate male crimp terminal (502579-0100)	75
X6...X12	Molex CLIK-Mate crimp terminal (502579-0100)	45

Table 3-28 EPOS4 MB Micro EtherCAT 3-axes Connector Set – Content

3.4.4 Tools

Tool	Manufacturer	Part Number
Hand crimper for CLIK-Mate crimp terminals	Molex	63819-4600
Hand crimper for Mega-Fit crimp terminals	Molex	63825-7100
Hand crimper for Micro-Fit 3.0 crimp terminals	Molex	63819-0000
Hand crimper for Mini-Fit crimp terminals	Molex	63819-0900

Table 3-29 Recommended tools

3.4.5 Connections

The power supply, logic supply, and EtherCAT interface for all axes are each merged in one consolidated connector. The axis-specific wiring is separately connected for up to three individual axes.

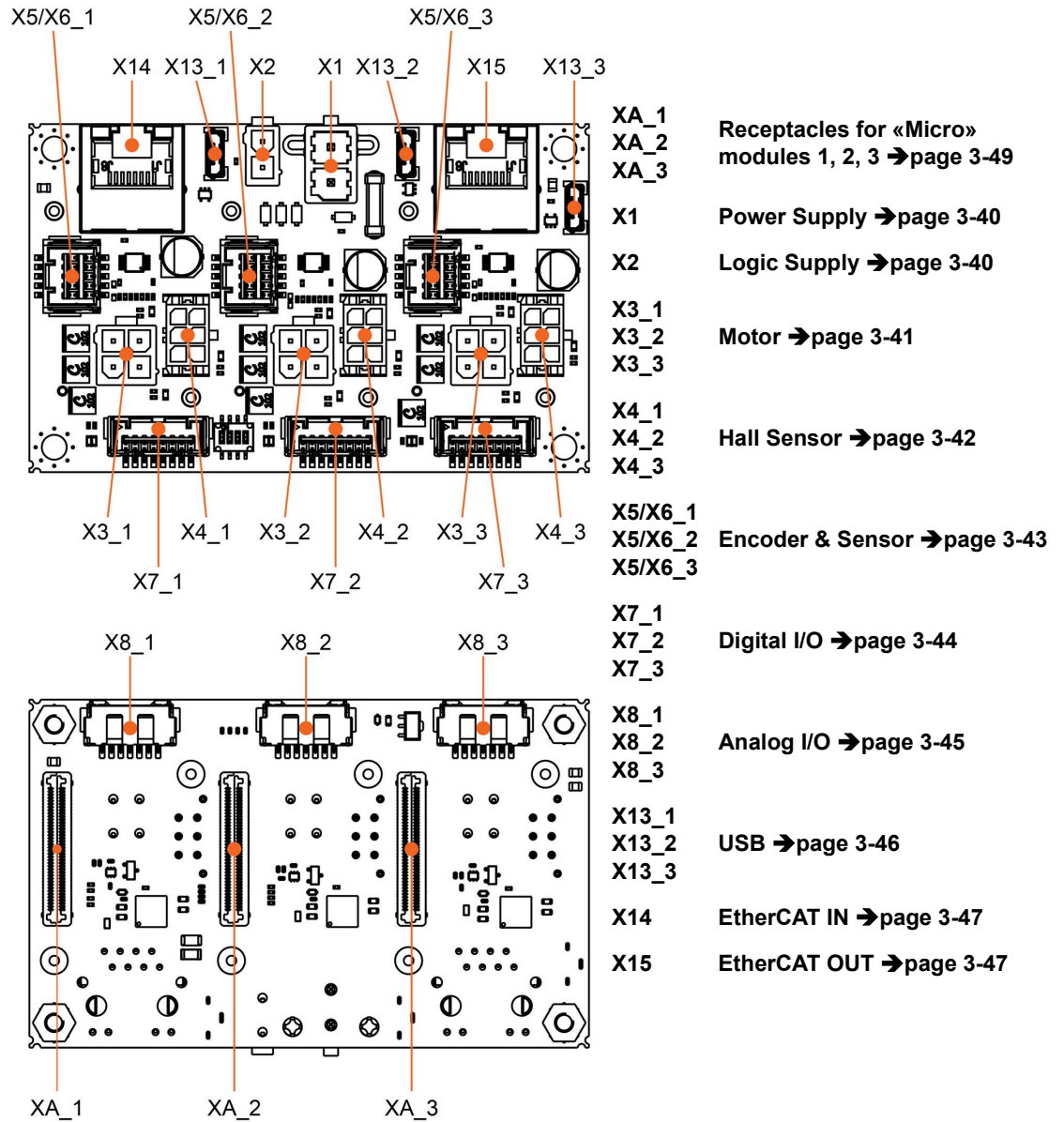

Figure 3-24 EPOS4 MB Micro EtherCAT 3-axes & EPOS4 Compact 24/5 EtherCAT 3-axes – Connectors



How to read pin assignment tables

- The first column describes both the pin number of the connector and of the matching prefab maxon cable's Head A.
- The second column describes the cable core color of the prefab maxon cable.
- The third column describes the pin number of the prefab maxon cable's Head B.
- For the matching prefab cable see →Table 3-27.

3.4.5.1 Power Supply (X1)



Best practice

Keep the motor mechanically disconnected during the setup and adjustment phase.

For the matching ready-made cable see →“Power Cable High Current (520850)” on page 3-70.

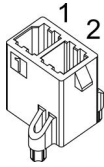

Figure 3-25 Power supply connector X1

X1 Head A Pin	Prefab Cable Color	Head B Pin	Signal	Description
1	black	-	GND	Ground
2	black	+	+V _{CC}	Power supply voltage (+10...+24 VDC)

Table 3-30 Power supply connector X1 – Pin assignment

3.4.5.2 Logic Supply (X2)



Separate power supply

The logic part of the controller may be supplied by separate supply voltage

- *Micro: The logic supply must be connected separately.*
- *EvaBo: If not supplied separately, the logic supply is internally connected to the power supply.*

For the matching ready-made cable see →“Power Cable (275829)” on page 3-70.

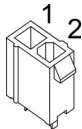

Figure 3-26 Logic supply connector X2

X2 Head A Pin	Prefab Cable Color	Head B Pin	Signal	Description
1	black	-	GND	Ground
2	black	+	+V _C	Logic supply voltage (+10...+24 VDC)

Table 3-31 Logic supply connector X2 – Pin assignment

3.4.5.3 Motor (X3_1 / X3_2 / X3_3)

The controller is set to drive either maxon EC motor (BLDC, brushless DC motor) or maxon DC motor (brushed DC motor) with separated motor/encoder cable.



Operation of up to three axis

With «MoBo» and «Compact», up to three individually connected axes can be operated. For easier legibility, "X3" stands for the connector X3_1, X3_2, and X3_3 of the respective axis.

For the matching ready-made cable see → "Motor Cable (275851)" on page 3-70.

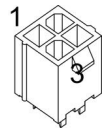

Figure 3-27 Motor connectors X3_1 / X3_2 / X3_3

X3 Head A Pin	Prefab Cable Color	Head B Pin	Signal	Description
1	white		Motor (+M)	DC motor: Motor +
2	brown		Motor (-M)	DC motor: Motor -
3	green		—	not connected
4	black		Motor shield	Cable shield

Table 3-32 Motor connector X3_1 / X3_2 / X3_3 – Pin assignment for maxon DC motor

X3 Head A Pin	Prefab Cable Color	Head B Pin	Signal	Description
1	white		Motor winding 1	EC motor: Winding 1
2	brown		Motor winding 2	EC motor: Winding 2
3	green		Motor winding 3	EC motor: Winding 3
4	black		Motor shield	Cable shield

Table 3-33 Motor connector X3_1 / X3_2 / X3_3 – Pin assignment for maxon EC motor

3.4.5.4 Hall Sensor (X4_1 / X4_2 / X4_3)



Operation of up to three axis

With «MoBo» and «Compact», up to three individually connected axes can be operated. For easier legibility, "X4" stands for the connector X4_1, X4_2, and X4_3 of the respective axis.

For the matching ready-made cable see → "Hall Sensor Cable (275878)" on page 3-70.

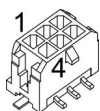

Figure 3-28 Hall sensor connector X4_1 / X4_2 / X4_3

X4 Head A Pin	Prefab Cable Color	Head B Pin	Signal	Description
1	green		Hall sensor 1	Hall sensor 1 input
2	brown		Hall sensor 2	Hall sensor 2 input
3	white		Hall sensor 3	Hall sensor 3 input
4	yellow		GND	Ground
5	grey		V _{Sensor}	Sensor supply voltage (+5 VDC; I _L ≤ 120 mA per axis)
6	black		Hall shield	Cable shield

Table 3-34 Hall sensor connector X4_1 / X4_2 / X4_3 – Pin assignment

3.4.5.5 Encoder/Sensor (X5/X6_1 / X5/X6_2 / X5/X6_3)



Configuration of digital encoder interface in «EPOS Studio»

The EPOS4 Micro 24/5 EtherCAT features a digital incremental encoder interface. For configuration select the option “X5 - Encoder (Digital incremental encoder 1)” «EPOS Studio». For the functionality of SSI interface and high-speed digital input and output, use connector X6.

For details on the deactivation of the incremental encoder index channel and the activation of the SSI functionality, respectively high-speed digital input 4 and high-speed digital output 1, consult →chapter “3.4.6.1 DIP Switch SW1” on page 3-48.



Operation of up to three axis

With «MoBo» and «Compact», up to three individually connected axes can be operated. For easier legibility, “X5/X6” stands for the combo connector X5/X6_1, X5/X6_2, and X5/X6_3 of the respective axis.

For matching ready-made cables see →“Sensor Cable 5x2core (520852)” on page 3-71 and →“Adapter Cable Encoder CLIK-Mate to DIN41651 (693573)” on page 3-72.

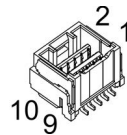

Figure 3-29 Encoder/Sensor combo connector X5/X6_1 / X5/X6_2 / X5/X6_3

X5/X6 Head A Pin	Prefab Cable Color	Head B Pin	Signal	Description
1	white		X5 Channel A	Channel A
2	brown		X5 Channel A\	Channel A complement
3	green		X5 Channel B	Channel B
4	yellow		X5 Channel B\	Channel B complement
5	grey		X5 Channel I	Channel I
			X6 Clock	Clock (SSI)
			X6 HsDigOUT1	High-speed digital output 1
6	pink		X5 Channel I\	Channel I complement
			X6 Clock\	Clock (SSI) complement
			X6 HsDigOUT1\	High-speed digital output 1 complement
7	blue		X6 Data	Data (SSI)
			X6 HsDigIN4	High-speed digital input 4
8	red		X6 Data\	Data (SSI) complement
			X6 HsDigIN4	High-speed digital input 4 complement
9	black		X5 GND	Ground
			X6 GND	
10	violet		X5 V _{Sensor}	Sensor supply voltage (+5 VDC; I _L ≤120 mA per axis)
			X6 V _{Sensor}	

Table 3-35 Encoder/Sensor combo connector X5/X6_1 / X5/X6_2 / X5/X6_3 – Pin assignment

3.4.5.6 Digital I/O (X7_1 / X7_2 / X7_3)



Operation of up to three axis

With «MoBo» and «Compact», up to three individually connected axes can be operated. For easier legibility, “X7” stands for the connector X7_1, X7_2, and X7_3 of the respective axis.

For the matching ready-made cable see →“Signal Cable 8core (520853)” on page 3-73.

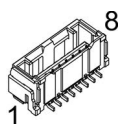

Figure 3-30 Digital I/O connector X7_1 / X7_2 / X7_3

X7 Head A Pin	Prefab Cable Color	Head B Pin	Signal	Description
1	white	1	DigIN1	Digital input 1
2	brown	2	DigIN2	Digital input 2
3	green	3	DigIN3	Digital input 3
4	yellow	4	DigIN4	Digital input 4
5	grey	5	DigOUT1	Digital output 1
6	pink	6	DigOUT2	Digital output 2
7	blue	7	GND	Ground
8	red	8	V _{Sensor}	Sensor supply voltage (+5 VDC; I _L ≤120 mA per axis)

Table 3-36 Digital I/O connector X7_1 / X7_2 / X7_3 – Pin assignment

3.4.5.7 Analog I/O (X8_1 / X8_2 / X8_3)**Operation of up to three axis**

With «MoBo» and «Compact», up to three individually connected axes can be operated. For easier legibility, “X8” stands for the connector X8_1, X8_2, and X8_3 of the respective axis.

For the matching ready-made cable see →“Signal Cable 7core (520854)” on page 3-73.

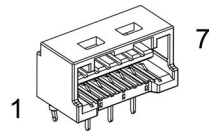

Figure 3-31 Analog I/O connector X8_1 / X8_2 / X8_3

X8 Head A Pin	Prefab Cable Color	Head B Pin	Signal	Description
1	white	1	AnIN1+	Analog input 1, positive signal
2	brown	2	AnIN1-	Analog input 1, negative signal
3	green	3	AnIN2+	Analog input 2, positive signal
4	yellow	4	AnIN2-	Analog input 2, negative signal
5	grey	5	AnOUT1	Analog output 1
6	pink	6	—	not connected
7	blue	7	GND	Ground

Table 3-37 Analog I/O connector X8_1 / X8_2 / X8_3 – Pin assignment

3.4.5.8 USB (X13_1 / X13_2 / X13_3)



Hot plugging the USB interface may cause hardware damage

If the USB interface is being hot-plugged (connecting while the power supply is on), the possibly high potential differences of the two power supplies of controller and PC/Notebook can lead to damaged hardware.

- Avoid potential differences between the power supply of controller and PC/Notebook or, if possible, balance them.
- Insert the USB connector first, then switch on the power supply of the controller.



Operation of up to three axis

With «MoBo» and «Compact», up to three individually connected axes can be operated. For easier legibility, «X13» stands for the connector X13_1, X13_2, and X13_3 of the respective axis.

For the matching ready-made cable see →“USB Type A - micro B Cable (403968)” on page 3-74.

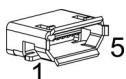

Figure 3-32 USB connector X13_1 / X13_2 / X13_3

Micro Header Pin	X13 Pin	PC's USB Terminal	Signal	Description
A58	X13 5	4	GND	USB ground
A59	X13 2	2	USB_D-	USB Data- (twisted pair with Data+)
A60	X13 1	1	V _{BUS}	USB bus supply voltage input +5 VDC
A61	X13 3	3	USB_D+	USB Data+ (twisted pair with Data-)
—	X13 4	—	ID	not connected

Table 3-38 USB connector X13_1 / X13_2 / X13_3 – Pin assignment

3.4.5.9 EtherCAT IN (X14) & EtherCAT OUT (X15)



Wrong plugging may cause hardware damage

Even though both EtherCAT sockets are prepared for identical external wiring, make sure to always connect them as follows.

- Use only standard Cat5 cables with RJ45 plug, such as maxon's «Ethernet Cable» (422827).
- Use EtherCAT IN (X14) as «Input».
- Use EtherCAT OUT (X15) as «Output».
- For configuration of a MoBo see →chapter “3.4.7 Axes Configuration on the Motherboard” on page 3-49. For detailed information see separate document →«EPOS4 Communication Guide».

For the matching ready-made cable see →“Ethernet Cable (422827)” on page 3-74.

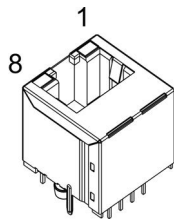

Figure 3-33 EtherCAT IN connector X14 & EtherCAT OUT connectorX15

X14 X15 Head A Pin	Prefab Cable Color	Head B Pin	Signal	Description
1	white/ orange	1	TX+	Transmission Data+
2	orange	2	TX-	Transmission Data-
3	white/ green	3	RX+	Receive Data+
4	blue	4	–	not applicable
5	white/ blue	5	–	not applicable
6	green	6	RX-	Receive Data-
7	white/ brown	7	–	not applicable
8	brown	8	–	not applicable

Table 3-39 EtherCAT IN connector X14 & EtherCAT OUT connectorX15 – Pin assignment

3.4.6 Switch Configuration

3.4.6.1 DIP Switch SW1

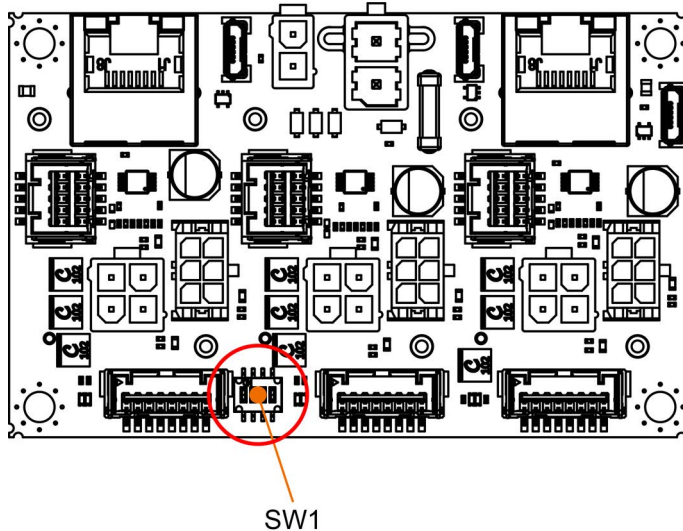

Figure 3-34 MoBo/Compact DIP switch SW1 – Location

The DIP switch SW1 functions are as follows:

- Switches 1, 2, and 3 configure the respective axis' combo connector «X5/X6_1», «X5/X6_2», and «X5/X6_3».
- Switch 4 sets the digital input level.



How to find the correct DIP switch setting

- To connect certain encoders to the combo connectors «X5/X6_1», «X5/X6_2», or «X5/X6_3», you will require an additional adapter.
For details on the adapter and its DIP switch configuration see →section “Adapter Cable Encoder CLIK-Mate to DIN41651 (693573)” on page 3-72.
- The **factory setting**—that is the respective axis' switch 1, 2, or 3 set to “OFF”—is used for a **digital incremental encoder with index channel in single loop control**. Thus, connection of an SSI absolute encoder or dual loop control are not supported.
For details on the combo connector(s) «X5/X6» DIP switch see →Table 3-40.
For wiring details see →chapter “5.3.7 Digital Incremental Encoder 1 (Sensor 1) on X5/X6” on page 5-102.
- For an **SSI encoder in single loop control** or **dual loop control**, set the respective axis' switch 1, 2, or 3 to “ON”. This setting will deactivate the index channel of a 3-channel digital Incremental encoder and connects the pins 5 and 6 of the combo connector «X5/X6_1», «X5/X6_2», or «X5/X6_3» to the SSI encoder's Clock and Clock\ signals.
This setup allows you to connect both SSI encoder and 2-channel/3-channel digital incremental encoder for dual loop control to the combo connector(s) «X5/X6» at the same time.
For details on the combo connector(s) «X5/X6» DIP switch see →Table 3-40.
For wiring details for single loop control see →chapter “5.3.8 SSI Encoder (Sensor 2) on X5/X6” on page 5-103.
For wiring details for dual loop control see →chapter “5.3.9 Digital Incremental Encoder (Sensor 1) and SSI Encoder (Sensor 2) on X5/X6” on page 5-103.

Continued on next page.

Default	Switch	Setting	
 (factory setting)	1	 ON OFF Axis 1:SSI encoder activated / incremental encoder index deactivated	
	2	 ON OFF Axis 2:SSI encoder activated / incremental encoder index deactivated	
	3	 ON OFF Axis 3:SSI encoder activated / incremental encoder index deactivated	
	4	 ON OFF Digital input level on all axes set to "Logic level"	 ON OFF Digital input level on all axes set to "PLC level"

Table 3-40 MoBo/Compact DIP switch SW1 – Settings

3.4.7 Axes Configuration on the Motherboard

The «MoBo» (659508) can host up to three «Micro» modules (654731) and is therefore ready to drive one, two, or three axes. For configuration, the following conventions apply:

ONE OR TWO AXIS:

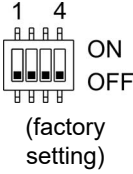
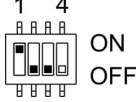
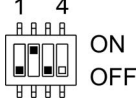
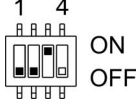
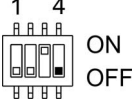
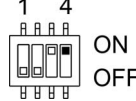
- The MoBo must be located at the last position of an EtherCAT dead-end branch line.
- It is not possible to install the MoBo with one or two axes in the middle of an EtherCAT network. In this configuration, EtherCAT OUT (X15) is not functional.
- The single Micro must be installed to the receptacle XA_1.
- The two Micros must be installed to the receptacles XA_1 and XA_2.
- EtherCAT IN (X14) must be connected, EtherCAT OUT (X15) must not be connected.

THREE AXES:

- The MoBo can be operated anywhere in the EtherCAT network.
- All three Micros must be installed in their respective receptacles XA_1, XA_2, and XA_3.
- If the MoBo is installed in the middle of an EtherCAT network, connect both EtherCAT IN (X14) and EtherCAT OUT (X15).
- If the MoBo is installed at the end of an EtherCAT network, connect EtherCAT IN (X14). EtherCAT OUT (X15) is not required unless cable redundancy is used.

3.5 Connection Specifications

The actual connection will depend on the overall configuration of your drive system and the type of motor you will be using. Follow the description in given order and choose the wiring diagram (→ as of page 5-93) that best suits the components you are using.



How to read the following data

The following tables feature, where applicable, connection details for both Micro and EvaBo, MoBo respectively. Thereby,...

- the column «Micro Header Pin» refers to the header's pin number.
Example: **A19...A24** means header A, pins 16 thru 24
- the column «EvaBo Connector Pin» refers to the connector's pin number.
Example: **X1 | 2** means connector X1, pin 2

For easier legibility, the subsequently used circuit diagrams refer to the Micro. For the EvaBo's circuitry take the second column «EvaBo Connector Pin» into account.

3.5.1 Power Supply

Basically, any power supply may be used provided that it meets the below stated minimum requirements.

Micro Header Pin	EvaBo / MoBo Connector Pin	Signal	Description
A19...A24**	X1 2	+V _{CC}	Power supply voltage (+10...+24 VDC)
A25**	X1 1	GND	Ground
A27...A32**			

** Connect all pins in respect to the individual pin current rating.

Table 3-41 Power supply – Pin assignment

Power supply requirements	
Output voltage	+V _{CC} 10...24 VDC
Absolute output voltage	min. 8 VDC; max. 28 VDC
Output current	Depending on load <ul style="list-style-type: none"> • continuous max. 5 A (per axis) • short-time (acceleration, <10 s) max. 15 A (per axis)

Table 3-42 Power supply requirements

- 1) Use the formula below to calculate the required voltage under load for each axis.
- 2) Choose a power supply according to the calculated voltage. Thereby consider:
 - a) During braking of the load, the power supply must be capable of buffering the recovered kinetic energy (for example, in a capacitor).
 - b) If you are using an electronically stabilized power supply, make sure that the overcurrent protection circuit is configured inoperative within the operating range.

Continued on next page.



The formula already takes the following into account:

- Maximum PWM duty cycle of 90%
- Controller's max. voltage drop of 1 V @ 5 A

KNOWN VALUES:

- Operating torque M [mNm]
- Operating speed n [rpm]
- Nominal motor voltage U_N [Volt]
- Motor no-load speed at U_N ; n_0 [rpm]
- Speed/torque gradient of the motor $\Delta n/\Delta M$ [rpm/mNm]

SOUGHT VALUE:

- Supply voltage $+V_{CC}$ [Volt]

SOLUTION:

$$V_{CC} \geq \left[\frac{U_N}{n_0} \cdot \left(n + \frac{\Delta n}{\Delta M} \cdot M \right) \cdot \frac{1}{0.9} \right] + 1[V]$$

3.5.2 Logic Supply



Separate power supply

The logic part of the controller may be supplied by separate supply voltage provided that it meets the below stated minimum requirements.

- *Micro:* The logic supply must be connected separately.
- *EvaBo / MoBo / Compact:* If not supplied separately, the logic supply is internally connected to the power supply.

Micro Header Pin	EvaBo / MoBo Connector Pin	Signal	Description
A25	X2 1	GND	Ground
A26	X2 2	$+V_c$	Logic supply voltage (+10...+24 VDC)

Table 3-43 Logic supply – Pin assignment

Power supply requirements		
Output voltage	$+V_c$ 10...24 VDC	
Absolute supply voltage	min. 8 VDC; max. 28 VDC	
Min. output power	Micro	P_c min. 3.5 W
	EvaBo	
	MoBo	P_c min. 10 W
	Compact	

Table 3-44 Logic supply requirements

3.5.3 Motor

The EPOS4 is set to drive either maxon DC motors (brushed) or maxon EC motors (brushless).



Operation of up to three axis

With «MoBo» and «Compact», up to three individually connected axes can be operated. For easier legibility, "X3" stands for the connector X3_1, X3_2, and X3_3 of the respective axis.

Micro Header Pin	EvaBo / MoBo Connector Pin	Signal	Description
A1...A6**	X3 1	Motor (+M)	Motor +
A7...A12**	X3 2	Motor (-M)	Motor -
—	X3 3	—	not connected
—	X3 4	Motor shield	Cable shield

** Connect all pins in respect to the individual pin current rating.

Table 3-45 DC motor – Pin assignment

Micro Header Pin	EvaBo / MoBo Connector Pin	Signal	Description
A1...A6**	X3 1	Motor winding 1	Winding 1
A7...A12**	X3 2	Motor winding 2	Winding 2
A13...A18**	X3 3	Motor winding 3	Winding 3
—	X3 4	Motor shield	Cable shield

** Connect all pins in respect to the individual pin current rating.

Table 3-46 EC motor – Pin assignment

3.5.4 Hall Sensor



Operation of up to three axis

With «MoBo» and «Compact», up to three individually connected axes can be operated. For easier legibility, "X4" stands for the connector X4_1, X4_2, and X4_3 of the respective axis.

Micro Header Pin	EvaBo / MoBo Connector Pin	Signal	Description
A27...A32	X4 4	GND	Ground
A33	X4 1	Hall sensor 1	Hall sensor 1 input
A35	X4 2	Hall sensor 2	Hall sensor 2 input
A37	X4 3	Hall sensor 3	Hall sensor 3 input
A39	X4 5	V_{Sensor}	Micro & EvaBo Sensor supply voltage (+5 VDC; $I_L \leq 145$ mA) MoBo & Compact Sensor supply voltage (+5 VDC; $I_L \leq 120$ mA per axis)
—	X4 6	Hall shield	Cable shield

Table 3-47 Hall sensor – Pin assignment

Hall sensor	
Sensor supply voltage (V_{Sensor})	+5 VDC
Input voltage	0...24 VDC
Max. input voltage	+24 VDC
Logic 0	typically <0.8 V
Logic 1	typically >2.0 V
Internal pull-up resistor	10 k Ω (referenced to +5.45 V)

Table 3-48 Hall sensor specification

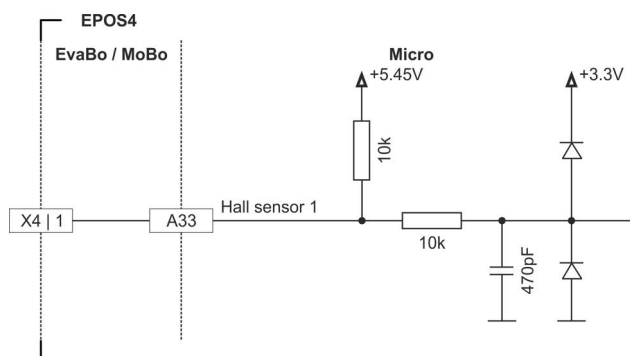

Figure 3-35 Hall sensor 1 input circuit (analogously valid for Hall sensors 2 & 3 and all axis)

3.5.5 Encoder



Best practice

- *Differential signals offer good resistance against electrical interference. Therefore, **we recommend using a differential scheme**. Nevertheless, the controller supports both schemes – differential and single-ended (unsymmetrical).*
- *For best performance, **we strongly recommend using encoders with a line driver**. Otherwise, limitations may apply due to slow switching edges.*
- *Even though 2-channel will do, **we strongly recommend to use only 3-channel versions**.*
- *With an SSI encoder, use of the digital incremental encoder's index channel is not possible.*



Operation of up to three axis

With «MoBo» and «Compact», up to three individually connected axes can be operated. For easier legibility, «X5/X6» stands for the combo connector X5/X6_1, X5/X6_2, and X5/X6_3 of the respective axis.

Micro Header Pin	EvaBo Connector Pin	MoBo Connector Pin	Signal	Description
A27...A32	X5 3	X5/X6 9	GND	Ground
A34	X5 6	X5/X6 1	Channel A	Digital incremental encoder channel A
A36	X5 5	X5/X6 2	Channel A\	Digital incremental encoder channel A complement
A38	X5 8	X5/X6 3	Channel B	Digital incremental encoder channel B
A39	X5 2	—	V _{Sensor}	Micro & EvaBo Sensor supply voltage (+5 VDC; I _L ≤145 mA)
—	—	X5/X6 10		MoBo & Compact Sensor supply voltage (+5 VDC; I _L ≤120 mA per axis)
A40	X5 7	X5/X6 4	Channel B\	Digital incremental encoder channel B complement
A42	X5 10	—	Channel I	Micro & EvaBo Digital incremental encoder channel I
—	—	X5/X6 5		MoBo & Compact DIP switch “OFF”
A44	X5 9	—	Channel I\	Micro & EvaBo Digital incremental encoder channel I complement
—	—	X5/X6 6		MoBo & Compact DIP switch “OFF”

Table 3-49 Encoder – Pin assignment

Encoder (differential)	
Sensor supply voltage (V_{Sensor})	+5 VDC
Min. differential input voltage	± 200 mV
Max. input voltage	± 12 VDC
Line receiver (internal)	EIA RS422 standard
Max. input frequency	6.25 MHz

Table 3-50 Differential encoder specification

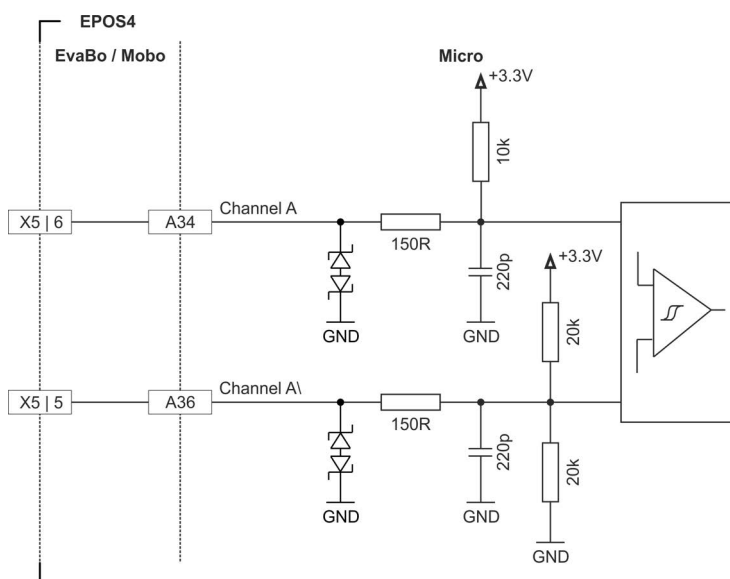

Figure 3-36 Encoder input circuit Ch A "differential" (analogously valid for Ch B & Ch I and all axis)

Encoder (single-ended)		
Sensor supply voltage (V_{Sensor})		+5 VDC
Input voltage		0...5 VDC
Max. input voltage		± 12 VDC
Logic 0		<1.0 V
Logic 1		>2.4 V
Input high current		I_{IH} = typically +250 μA @ 5 V
Input low current		I_{IL} = typically -330 μA @ 0 V
Max. input frequency	Push-pull	6.25 MHz
	Open collector	40 kHz (internal pull-up only) 150 kHz (additional external 3k3 pull-up)

Table 3-51 Single-ended encoder specification

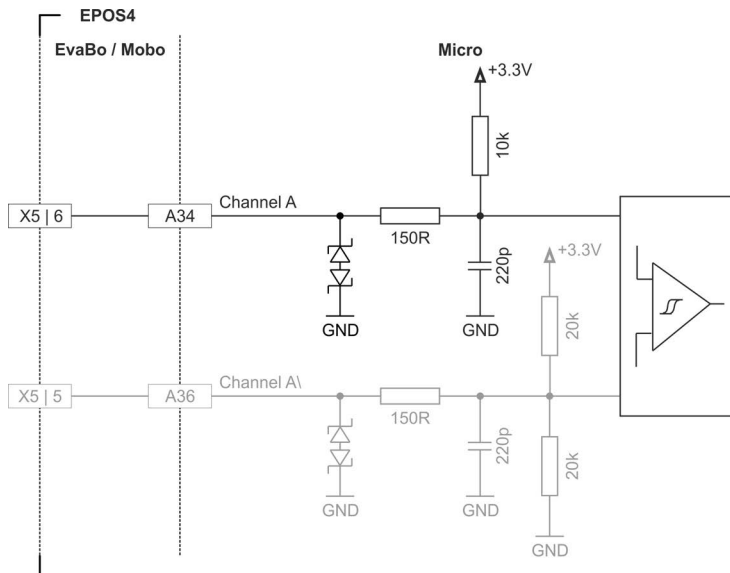

Figure 3-37 Encoder input circuit Ch A "single-ended" (analogously valid for Ch B & Ch I and all axis)

3.5.6 Sensor



Operation of up to three axis

With «MoBo» and «Compact», up to three individually connected axes can be operated. For easier legibility, “X5/X6” stands for the combo connector X5/X6_1, X5/X6_2, and X5/X6_3 of the respective axis.

3.5.6.1 SSI Absolute Encoder

Micro Header Pin	EvaBo Connector Pin	MoBo Connector Pin	Signal	Description
A39	X6 10 [d]	X5/X6 10	V_{Sensor}	Micro & EvaBo Sensor output voltage (+5 VDC; $I_L \leq 145$ mA)
—		—	V_{DD}	MoBo & Compact Sensor supply voltage (+5 VDC; $I_L \leq 120$ mA per axis)
—	—	—	V_{DD}	Auxiliary output voltage (+5 VDC; $I_L \leq 300$ mA)
A53	X6 7	X5/X6 7	Data	Data (SSI)
—	X6 8	X5/X6 8	Data\	Data (SSI) complement
A55	X6 5	X5/X6 5	Clock	Clock (SSI)
—	X6 6	X5/X6 6	Clock\	Clock (SSI) complement
A57	X6 9	X5/X6 7	GND	Ground

[d] switchable between V_{Sensor} and V_{DD} using switch SW2 on the EvaBo

Table 3-52 SSI absolute encoder – Pin assignment

SSI absolute encoder (Micro)	
Auxiliary output voltage	+5 VDC
Max. supply current	V_{Sensor} 145 mA
Input voltage	0...3.3 VDC
Max. input voltage	3.3 VDC
High-level input voltage	>2.0 VDC
Low-level input voltage	<0.8 VDC
High-level output voltage	>2.4 VDC
Low-level output voltage	<0.4 VDC

Table 3-53 SSI absolute encoder specification (Micro)

Continued on next page.

SSI absolute encoder (EvaBo)	
Auxiliary output voltage	+5 VDC
Max. supply current	V_{DD} 300 mA / V_{Sensor} 145 mA
Min. differential input voltage	± 200 mV
Min. differential output voltage	± 1.8 V @ external load $R=54 \Omega$
Max. output current	40 mA
Line receiver (internal)	EIA RS422 standard
Encoder input/output frequency	0.4... 2 MHz

Table 3-54 SSI absolute encoder specification (EvaBo)

SSI absolute encoder (MoBo)	
Auxiliary output voltage	+5 VDC
Max. supply current	V_{Sensor} 120 mA per axis
Min. differential input voltage	± 200 mV
Min. differential output voltage	± 1.8 V @ external load $R=54 \Omega$
Max. output current	40 mA
Line receiver (internal)	EIA RS422 standard
Encoder input/output frequency	0.4... 2 MHz
DIP switch position	"ON"

Table 3-55 SSI absolute encoder specification (MoBo)

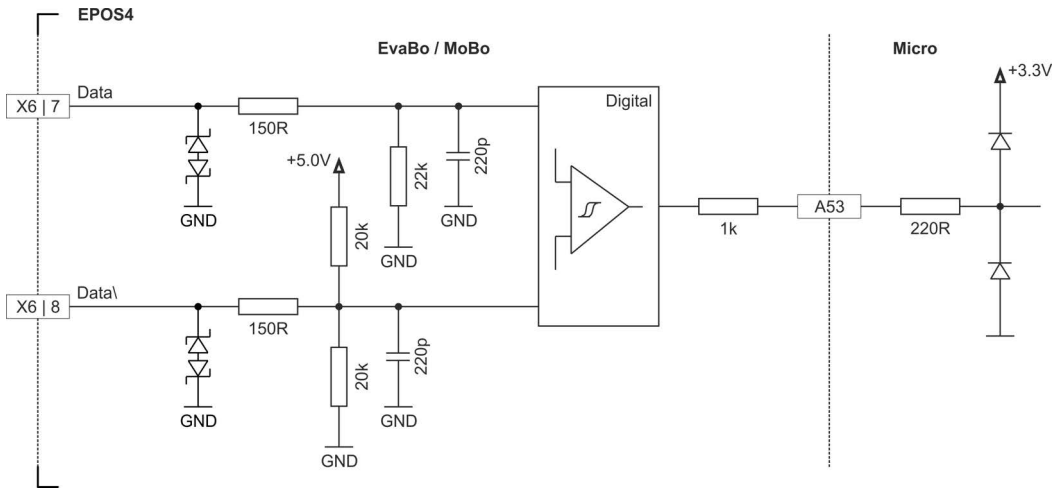

Figure 3-38 SSI absolute encoder data input

Continued on next page.

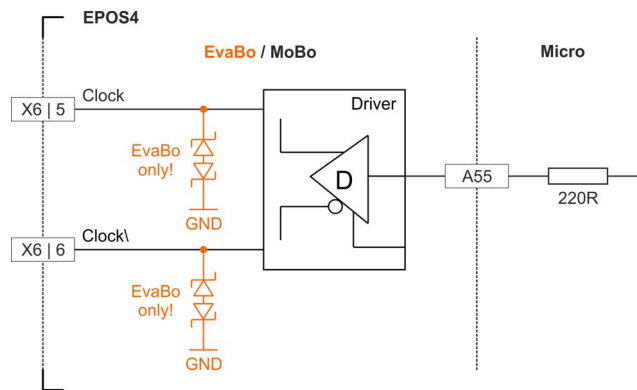

Figure 3-39 SSI absolute encoder clock output

3.5.6.2 High-speed Digital I/Os

Alternatively, the sensor interface can be used for high-speed digital I/O operation.

Micro Header Pin	EvaBo Connector Pin	MoBo Connector Pin	Signal	Description
A39	X6 10 [d]	X5/X6 10	V_{Sensor}	Micro & EvaBo Sensor output voltage (+5 VDC; $I_L \leq 145 \text{ mA}$)
—		—	V_{DD}	MoBo & Compact Sensor supply voltage (+5 VDC; $I_L \leq 120 \text{ mA per axis}$)
A53	X6 7	X5/X6 7	HsDigIN4	Auxiliary output voltage (+5 VDC; $I_L \leq 300 \text{ mA}$)
—	X6 8	X5/X6 8	HsDigIN4\	High-speed digital input 4
A55	X6 5	X5/X6 5	HsDigOUT1	High-speed digital input 4 complement
—	X6 6	X5/X6 6	HsDigOUT1\	High-speed digital output 1
A57	X6 9	X5/X6 9	GND	High-speed digital output 1 complement
Ground				

[d] switchable between V_{Sensor} and V_{DD} using switch SW2 on the EvaBo

Table 3-56 High-speed digital I/Os – Pin assignment

High-speed digital input 4 (differential)	
Max. input voltage	±12 VDC
Min. differential input voltage	±200 mV
Line receiver (internal)	EIA RS422 standard
Max. input frequency	6.25 MHz

Table 3-57 Differential high-speed digital input specification

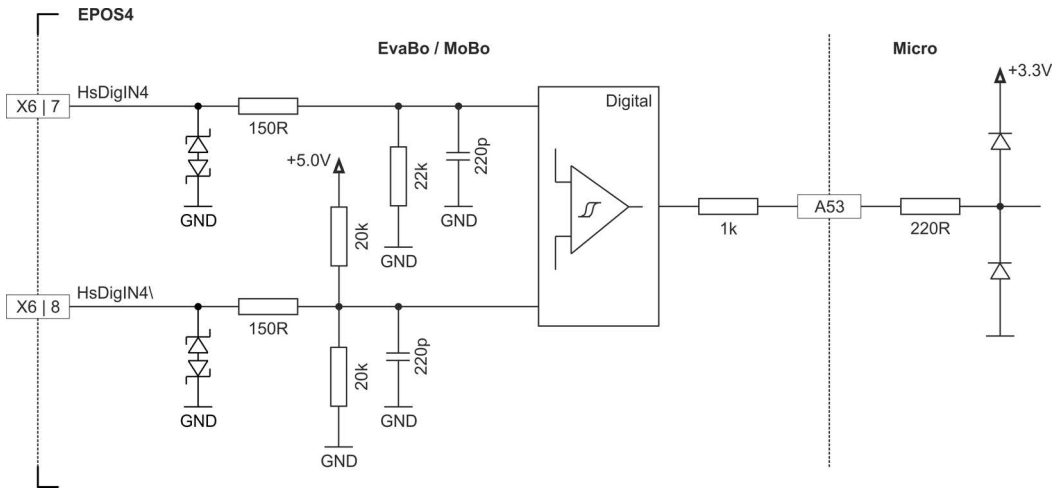

Figure 3-40 HsDigIN4 circuit “differential”

High-speed digital input 4 (Micro, single-ended)	
Input voltage	0...3.3 VDC
Max. input voltage	3.3 VDC
Logic 0	<0.8 V
Logic 1	>2.0 V
Max. input frequency	6.25 MHz

Table 3-58 Single-ended high-speed digital input specification (Micro)

High-speed digital input 4 (EvaBo, single-ended)	
Input voltage	0...5 VDC
Max. input voltage	±12 VDC
Logic 0	<1.0 V
Logic 1	>3.0 V
Max. input frequency	6.25 MHz

Table 3-59 Single-ended high-speed digital input specification (EvaBo)

Continued on next page.

High-speed digital input 4 (MoBo, single-ended)	
Input voltage	0...5 VDC
Max. input voltage	±12 VDC
Logic 0	<1.0 V
Logic 1	>3.0 V
Max. input frequency	6.25 MHz
DIP switch SW1 position	“ON”

Table 3-60 Single-ended high-speed digital input specification (MoBo)

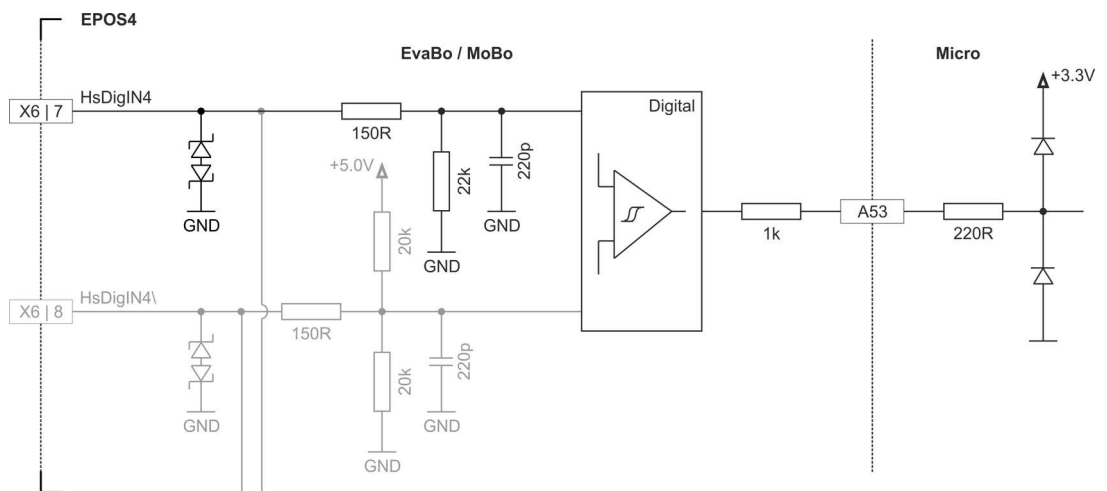

Figure 3-41 HsDigIN4 circuit “single-ended”

High-speed digital output 1 (Micro, single-ended)	
High-level output voltage	>2.4 VDC
Low-level output voltage	<0.4 VDC
Max. output current	≤2 mA

Table 3-61 High-speed digital output specification (EvaBo)

High-speed digital output 1 (EvaBo, differential)	
Min. differential output voltage	±1.8 V @ external load R=54 Ω
Max. output current	40 mA
Line transceiver (internal)	EIA RS422 standard
Max. output frequency	6.25 MHz

Table 3-62 High-speed digital output specification (EvaBo)

High-speed digital output 1 (MoBo, differential)	
Min. differential output voltage	$\pm 1.8 \text{ V @ external load } R=54 \Omega$
Max. output current	40 mA
Line transceiver (internal)	EIA RS422 standard
Max. output frequency	6.25 MHz
DIP switch SW1 position	“ON”

Table 3-63 High-speed digital output specification (MoBo)

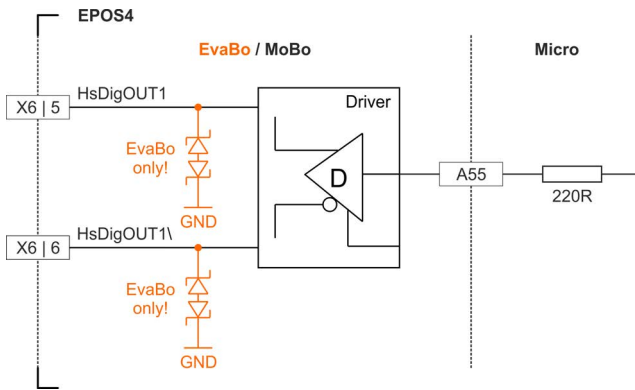

Figure 3-42 HsDigOUT1 output circuit

3.5.7 Digital I/Os

3.5.7.1 Digital Inputs Micro

Micro Header Pin	Signal	Description
A39	V_{Sensor}	Sensor output voltage (+5 VDC; $I_L \leq 145$ mA)
A41	DigIN1	Digital input 1
A43	DigIN2	Digital input 2
A45	DigIN3	Digital input 3
A47	DigIN4	Digital input 4
A57	GND	Ground

Table 3-64 Digital inputs – Pin assignment – Micro

Digital inputs 1...4 (Micro)	
Input voltage	0...36 VDC
Max. input voltage	± 36 VDC
Logic 0	<0.8 V
Logic 1	>2.1 V
Input resistance	typically 47 k Ω (<3.3 V) typically 37.5 k Ω (@ 5 V) typically 25.5 k Ω (@ 24 V)
Input current at logic 1	typically 135 μ A @ +5 VDC
Switching delay	<300 μ s

Table 3-65 Digital input specification – Micro

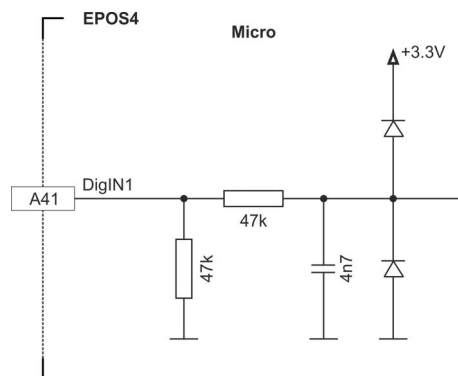

Figure 3-43 DigIN1 circuit (analogously valid for DigIN2...4) – Micro

3.5.7.2 Digital Inputs EvaBo & MoBo



Operation of up to three axis

With «MoBo» and «Compact», up to three individually connected axes can be operated. For easier legibility, «X7» stands for the connector X7_1, X7_2, and X7_3 of the respective axis.

EvaBo / MoBo Connector Pin	Signal	Description
X7 1	DigIN1	Digital input 1
X7 2	DigIN2	Digital input 2
X7 3	DigIN3	Digital input 3
X7 4	DigIN4	Digital input 4
X7 7	GND	Ground
X7 8 [d]	V_{Sensor}	Sensor output voltage (+5 VDC; $I_L \leq 120$ mA per axis)
	V_{DD}	Auxiliary output voltage (+5 VDC; $I_L \leq 300$ mA)

[d] switchable between V_{Sensor} and V_{DD} using switch SW2 on the EvaBo

Table 3-66 Digital inputs – Pin assignment – EvaBo

Digital inputs 1...4 (EvaBo & MoBo / Logic level setting)	
Input voltage	0...30 VDC
Max. input voltage	± 30 VDC
Logic 0	<0.8 V
Logic 1	>2.0 V
Input current at logic 1	250 μ A @ 5 VDC
Switching delay	<300 μ s @ 5 VDC
DIP switch SW1 position	“OFF”

Table 3-67 Digital input specification – Logic level setting

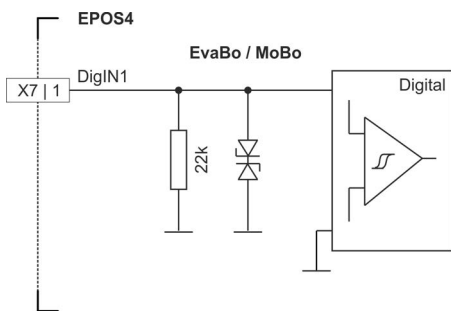

Figure 3-44 DigIN1 circuit (analogously valid for DigIN2...4) – EvaBo & MoBo / Logic level setting

Digital inputs 1...4 (EvaBo & MoBo / PLC level setting)	
Input voltage	0...30 VDC
Max. input voltage	±30 VDC
Logic 0	<5.5 V
Logic 1	>9 V
Input current at logic 1	>2 mA @ 9 VDC typically 3.5 mA @ 24 VDC
Switching delay	<300 μs @ 24 VDC
DIP switch position	"ON"

Table 3-68 Digital input specification – PLC level setting

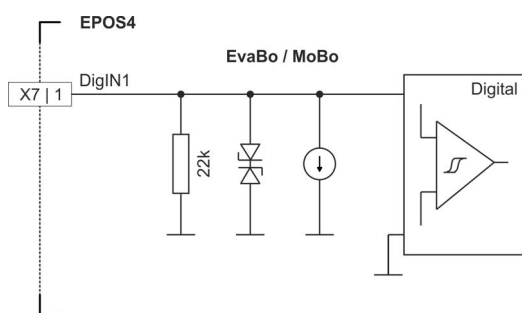

Figure 3-45 DigIN1 circuit (analogously valid for DigIN2...4) – EvaBo & MoBo / PLC level setting

3.5.7.3 Digital Outputs

Micro Header Pin	EvaBo / MoBo Connector Pin	Signal	Description
A49	X7 5	DigOut1	Digital output 1
A51	X7 6	DigOut2	Digital output 2
A57	X7 7	GND	Ground

Table 3-69 Digital outputs – Pin assignment – Micro

Digital outputs 1...2	
Circuit	Open drain (internal pull-up resistor 2k2 and diode to +5.45 VDC)

Table 3-70 Digital output specification

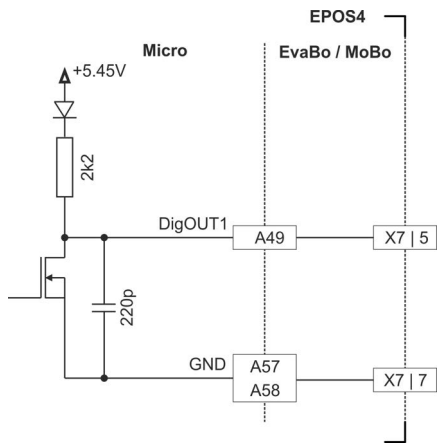

Figure 3-46 DigOUT1 circuit (analogously valid for DigOUT2)

WIRING EXAMPLES

DigOUT "sinks"	
Max. input voltage	+36 VDC
Max. load current	500 mA
Max. voltage drop	0.5 V @ 500 mA
Max. load inductance	100 mH @ 24 VDC; 500 mA

Table 3-71 Digital output – Sinks

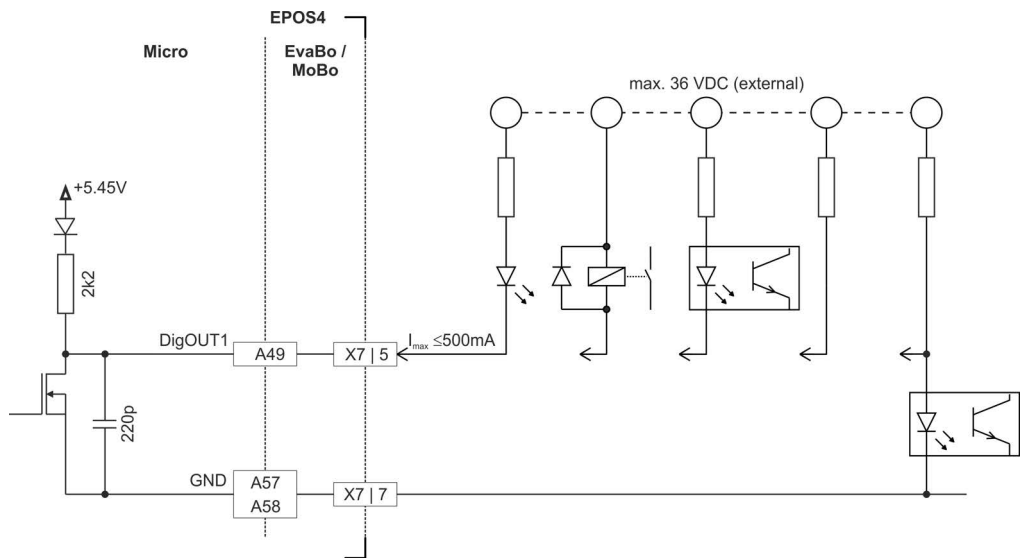

Figure 3-47 DigOUT1 "sinks" (analogously valid for DigOUT2 and EvaBo & MoBo)

DigOUT "source"	
Output voltage	$U_{Out} = 5.45\text{ V} - 0.75\text{ V} - (I_{Load} \times 2200\ \Omega)$
Max. load current	$I_{Load} \leq 2\text{ mA}$

Table 3-72 Digital output – Source

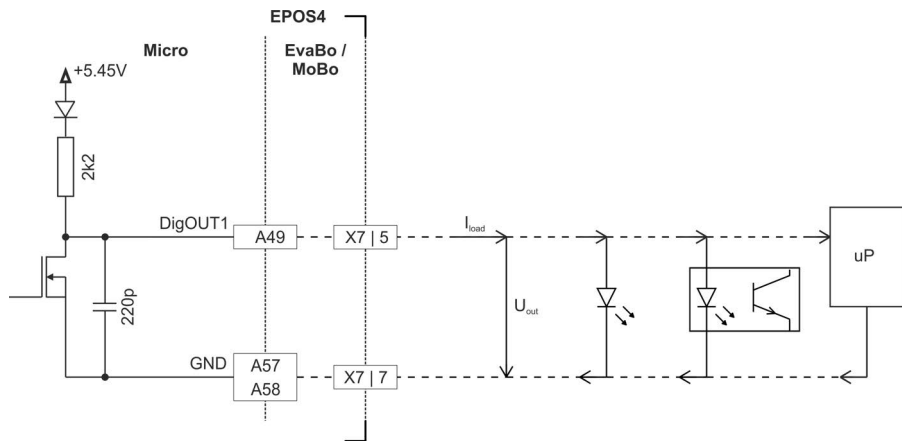

Figure 3-48 DigOUT1 "source" (analogously valid for DigOUT2 and EvaBo & MoBo)

3.5.8 Analog I/Os



Operation of up to three axis

With «MoBo» and «Compact», up to three individually connected axes can be operated. For easier legibility, «X8» stands for the connector X8_1, X8_2, and X8_3 of the respective axis.

Micro Header Pin	EvaBo / MoBo Connector Pin	Signal	Description
A46	X8 1	AnIN1+	Analog input 1, positive signal
A48	X8 2	AnIN1-	Analog input 1, negative signal
A50	X8 3	AnIN2+	Analog input 2, positive signal
A52	X8 4	AnIN2-	Analog input 2, negative signal
A54	X8 5	AnOUT1	Analog output 1
A57	X8 7	GND	Ground
A58			

Table 3-73 Analog I/Os – Pin assignment

Analog input 1...2	
Input voltage	±10 VDC (differential)
Max. input voltage	±24 VDC
Common mode voltage	-5...+10 VDC (referenced to GND)
Input resistance	80 kΩ (differential) 65 kΩ (referenced to GND)
A/D converter	12-bit
Resolution	5.64 mV
Bandwidth	10 kHz

Table 3-74 Analog input specification

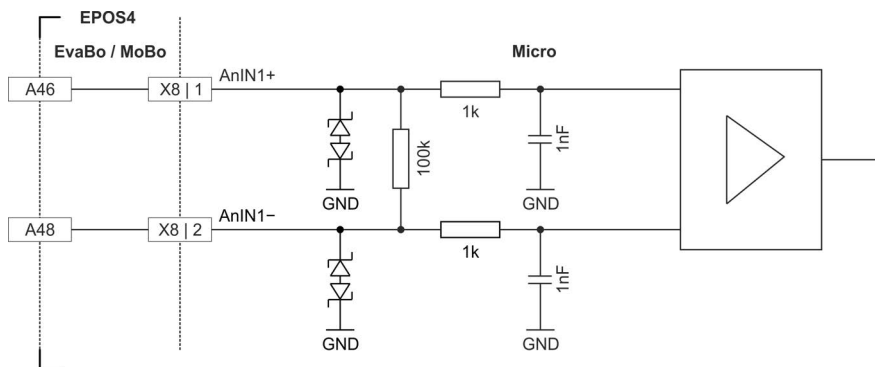

Figure 3-49 AnIN1 circuit (analogously valid for AnIN2)

Analog output 1	
Output voltage	±4 VDC
D/A converter	12-bit
Resolution	2.42 mV
Refresh rate	2.5 kHz
Analog bandwidth of output amplifier	25 kHz
Max. capacitive load	300 nF Note: The increase rate is limited in proportion to the capacitive load (e.g. 5 V/ms @ 300 nF)
Max. output current limit	1 mA

Table 3-75 Analog output specification

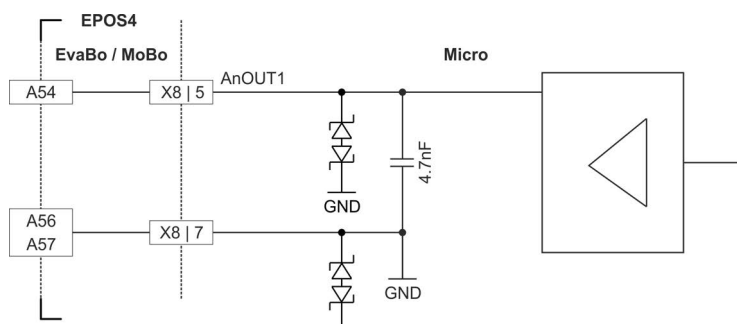

Figure 3-50 AnOUT1 circuit

3.5.9 USB

USB	
USB Standard	USB 2.0 / USB 3.0 (full speed)
Max. bus supply voltage	+5.25 VDC
Max. DC data input voltage	-0.5...+3.8 VDC

Table 3-76 USB interface specification

3.6 Prefab Cable Assemblies

Power Cable (275829)			
A			B
Cross-section	2 x 0.75 mm ² , grey		
Length	3 m		
Head A	Plug	Molex Mini-Fit Jr., 2 poles (39-01-2020)	
	Contacts	Molex Mini-Fit Plus crimp terminals (45750)	
Head B	Wire end sleeves 0.75 mm ²		

Table 3-77 Power Cable

Power Cable High Current (520850)			
A			B
Cross-section	2 x 2.5 mm ² , grey		
Length	3 m		
Head A	Plug	Molex Mega-Fit, 2 poles (171692-0102)	
	Contacts	Molex Mega-Fit, female crimp terminals (172063)	
Head B	Wire end sleeves 2.5 mm ²		

Table 3-78 Power Cable High Current

Motor Cable (275851)			
A			B
Cross-section	3 x 0.75 mm ² , shielded, grey		
Length	3 m		
Head A	Plug	Molex Mini-Fit Jr., 4 poles (39-01-2040)	
	Contacts	Molex Mini-Fit Plus crimp terminals (45750)	
Head B	Wire end sleeves 0.75 mm ²		

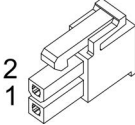
Table 3-79 Motor Cable

Hall Sensor Cable (275878)		
A		B
Cross-section	5 x 0.14 mm ² , shielded, grey	

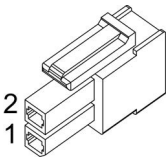
Hall Sensor Cable (275878)		
Length	3 m	
Head A	Plug	Molex Micro-Fit 3.0, 6 poles (430-25-0600)
	Contacts	Molex Micro-Fit 3.0 female crimp terminals (430-30-xxxx)
Head B	Wire end sleeves 0.14 mm ²	

Table 3-80 Hall Sensor Cable

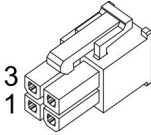
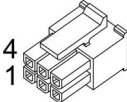
Encoder Cable (275934)	
<div style="display: flex; justify-content: space-between; align-items: center;"> <div style="text-align: center;">  <p>A</p> </div> <div style="text-align: center;">  <p>B</p> </div> </div>	
Cross-section	10 x AWG28, round-jacket, flat cable, pitch 1.27 mm
Length	3 m
Head A	DIN 41651 female, pitch 2.54 mm, 10 poles, with strain relief
Head B	DIN 41651 plug, pitch 2.54 mm, 10 poles, with strain relief

Table 3-81 Encoder Cable

Sensor Cable 5x2core (520852)		
<div style="display: flex; justify-content: space-between; align-items: center;"> <div style="text-align: center;">  <p>A</p> </div> <div style="text-align: center;"> <p>B</p> </div> </div>		
Cross-section	5 x 2 x 0.14 mm ² , twisted pair, grey	
Length	3 m	
Head A	Plug	Molex CLIK-Mate, dual row, 10 poles (503149-1000)
	Contacts	Molex CLIK-Mate crimp terminals (502579)
Head B	Wire end sleeves 0.14 mm ²	

Table 3-82 Sensor Cable 5x2core

Adapter Cable Encoder CLIK-Mate to DIN41651 (693573)		
Cable	Cross-section	5 x 2 x 0.14 mm ² , LiYY (TP)
	Length	0.3 m
	Conectors	Molex CLIK-Mate, 2 rows, 10 poles (503149100) Molex CLIK-Mate, 1 row, 10 poles (5025781000)
Connector PCB	X1	Molex CLIK-Mate, 1 row, 10 poles, pitch 1.50 mm (5025851070)
	X2 [c]	DIN 41651 10 poles, pitch 2.54 mm
	X3 [c]	Molex CLIK-Mate 2 rows, 10 poles, pitch 1.50 mm (5031481090)

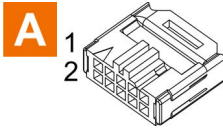
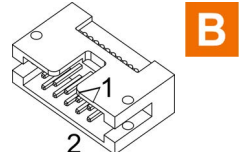
X2 Pin	Singe loop [d]	Dual loop [e]	X3 Pin	Singe loop [d]	Dual loop [e]
X2 1	—	—	X3 1	—	—
X2 2	V _{Sensor} [f]	V _{Sensor} [f]	X3 2	—	—
X2 3	GND	GND	X3 3	—	—
X2 4	—	—	X3 4	—	—
X2 5	Channel A\	Channel A\	X3 5	—	Clock
X2 6	Channel A	Channel A	X3 6	—	Clock\
X2 7	Channel B\	Channel B\	X3 7	—	Data
X2 8	Channel B	Channel B	X3 8	—	Data\
X2 9	Channel I\	—	X3 9	—	GND
X2 10	Channel I	—	X3 10	—	V _{ext} [f]

[c] maxon standard assignment

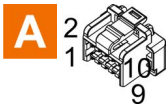
[d] 3-channel incremental encoder on X2 / SW1 switch 1, 2 “ON”

[e] 2-channel incremental encoder on X2 and SSI absolute encoder on X3 / SW1 switch 1, 2 “OFF”

[f] The internal sensor supply V_{Sensor} is +5 VDC; I_L ≤ 120 mA. If the required sensor supply exceeds 120 mA, the external supply V_{ext} must be connected and SW1 switch 4 must be set to “ON”.

Table 3-83 Adapter Cable Encoder CLIK-Mate to DIN41651

Continued on next page.

Default	Switch	Setting		
 (factory setting)	1, 2, 4	 ON OFF	Single loop: 3-channel incremental encoder through-connected from X2 to X1 / X1 connected to combo connector X5/X6	
	1, 2	 ON OFF	Dual loop: 2-channel incremental encoder on X2 / SSI absolute encoder on X3 / X1 connected to combo connector X5/X6	
	4	 ON OFF	Internal sensor supply voltage V_{Sensor} (+5 VDC; $I_L \leq 120$ mA) for X3 is turned on	 ON OFF

Table 3-84 Adapter Cable Encoder CLIK-Mate to DIN41651 DIP switch SW1 – Settings



Signal Cable 8core (520853)		
 A 8 1	 B	
Cross-section	8 x 0.14 mm ² , grey	
Length	3 m	
Head A	Plug	Molex CLIK-Mate, single row, 8 poles (502578-0800)
	Contacts	Molex CLIK-Mate crimp terminals (502579)
Head B	Wire end sleeves 0.14 mm ²	

Table 3-85 Signal Cable 8core

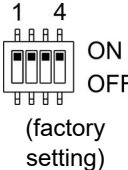
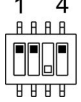
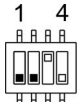
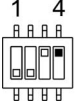
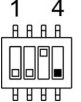

Signal Cable 7core (520854)		
 A 7 1	 B	
Cross-section	7 x 0.14 mm ² , grey	
Length	3 m	
Head A	Plug	Molex CLIK-Mate, single row, 7 poles (502578-0700)
	Contacts	Molex CLIK-Mate crimp terminals (502579)
Head B	Wire end sleeves 0.14 mm ²	

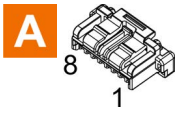
Table 3-86 Signal Cable 7core

USB Type A - micro B Cable (403968)	
Cross-section	According to USB 2.0 / USB 3.0 specification
Length	1.5 m
Head A	USB Type "micro B", male
Head B	USB Type "A", male

Table 3-87 USB Type A - micro B Cable

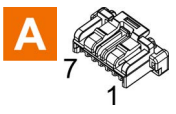
Ethernet Cable (422827)	
Cross-section	Cat. 5e SF/UTP (ISO/IEC 11801), 1:1 patch cable, green
Length	2 m
Head A	RJ45 (8P8CS) EIA/TIA-568B
Head B	RJ45 (8P8CS) EIA/TIA-568B

Table 3-88 Ethernet Cable

3.7 Status Indicators

The EPOS4 features three sets of LED indicators to display the device condition.

- A NET Status;** the LEDs display communication RUN states and errors conditions
- B Device Status;** the LEDs display the device's operation status and error conditions
- C EtherCAT Port;** the LED displays the NET link activity

For detailed information see separate document →«EPOS4 Firmware Specification».

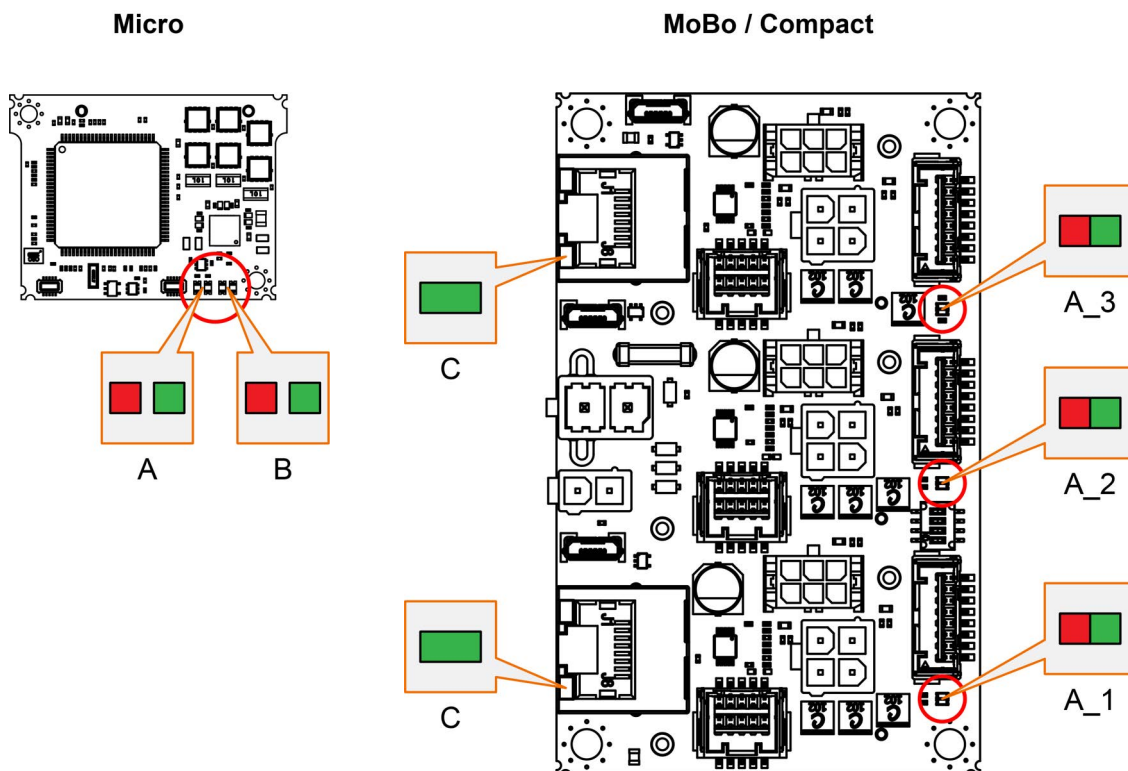

Figure 3-51 LEDs – Location

3.7.1 NET Status

The LEDs (→Figure 3-51; **A**) display the actual status and possible errors of the EPOS4 in respect to the NET network:

- Green LED shows the RUN state
- Red LED indicates errors

LED		Description
Green	Red	
OFF	—	EPOS4 is in state INIT
Blink	—	EPOS4 is in state PRE-OPERATIONAL
Single flash	—	EPOS4 is in state SAFE-OPERATIONAL
ON	—	EPOS4 is in state OPERATIONAL
Flicker	—	EPOS4 is in state BOOTSTRAP
—	OFF	EPOS4 is in operating condition
—	Double flash	An application watchdog timeout has occurred <i>Example: Timeout of Sync Manager Watchdog</i>
—	Single flash	EPOS4 has changed the COM state due to an internal error <i>Example: Change of state “Op” to “SafeOpError” due to Sync Error</i>
—	Blink	General Configuration Error <i>Example: State change commanded by master is not possible due to actual settings (register, object, hardware configuration)</i>
Blink = continuous blinking (≈2.5 Hz) Flash = flashing (≈0.2 s), followed by pause of 1 s Flicker = continuous flickering (≈10Hz)		

Table 3-89 NET Status LEDs

3.7.2 Device Status

The LEDs (→Figure 3-51; **B**) display the actual status and possible errors of the EPOS4:

- Green LED shows the status
- Red LED indicates errors

LED		Description
Green	Red	
Slow	OFF	Power stage is disabled. The EPOS4 is in status... • “Switch ON Disabled” • “Ready to Switch ON” • “Switched ON”
ON	OFF	Power stage is enabled. The EPOS4 is in status... • “Operation Enable” • “Quick Stop Active”
OFF	ON	FAULT state. The EPOS4 is in status... • “Fault”
ON	ON	Power stage is enabled. The EPOS4 is in temporary status... • “Fault Reaction Active”
Flash	ON	No valid firmware or firmware download in progress
Flash = flashing (≈0.9 s OFF/≈0.1 s ON) Slow = slow blinking (≈1 Hz)		

Table 3-90 Device Status LEDs

3.7.3 EtherCAT Port

The LED (→Figure 3-51; **C**) displays the link activity of the EtherCAT port (applies for both ports, X14 “IN” and X15 “OUT”):

- Green LED indicates link activity

LED Green	Description
OFF	Port is closed
Flicker	Port is open / activity is present
ON	Port is open
—	Data rate is 100 Mbit/s
Flicker = continuous flickering (≈10 Hz)	

Table 3-91 EtherCAT Port LED

••page intentionally left blank••

4 MOTHERBOARD DESIGN GUIDE

The «Motherboard Design Guide» provides helpful information on integrating the Micro on a printed circuit board. It contains recommendations for the motherboard layout and specifies external components that may be required, pin assignments, and connection examples.



CAUTION

Dangerous Action

Errors in implementing the design can result in serious Injury!

- Only proceed if you are skilled in electronics design!
- Designing a printed circuit board requires special skills and knowledge and may only be performed by experienced electronic developers!
- This quick guide is only intended as an aid, does not make any claim to completeness, and will not automatically result in a functional component!



Get help

If you are not trained in the design and development of printed circuit boards, you will need additional support for this point.

maxon will be happy to provide you with a quote for designing and manufacturing a motherboard for your specific application.

4.1 Requirements for Components of Third-party Suppliers



Best practice

For references and recommended components consult →Table 4-96.

4.1.1 Terminal/Socket Combo Strip

For implementation of the Micro, a terminal/socket combo strip is required.

4.1.2 Spacers

For implementation of the Micro, two 5 mm long spacers with M2 threads are required. For respective matching types, see →“Recommended Components and Manufacturers” on page 4-88, for their locations and footprint see →Figure 4-63 on page 4-92.

4.1.3 Supply Voltage

To protect the Micro, we recommend using an external circuit breaker, a TVS diode, and a capacitor in the voltage supply line. In this regard, please note the following recommendations:

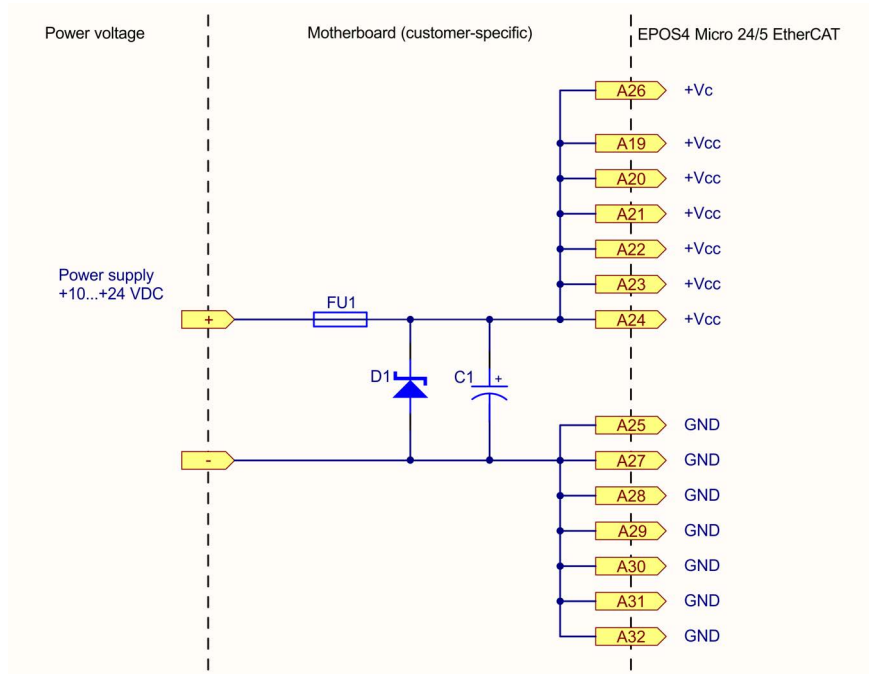

Figure 4-52 Wiring of power supply

INPUT FUSE (FU1)

An input fuse (FU1) is necessary in order to provide reverse polarity protection. Together with an unipolar TVS diode (D1), this prevents current from flowing in the wrong direction.

TVS DIODE (D1)

To protect against overvoltage resulting from voltage transients, we recommend to connect a TVS (transient voltage suppressor) diode (D1) to the voltage supply line.

CAPACITOR (C1)

The function of the Module does not necessarily require the use of an external capacitor. Nevertheless, to further reduce voltage ripple or to buffer feedback currents (typically present during motor deceleration), an electrolytic capacitor (C1) can be connected to the voltage supply line. Use of an electrolytic capacitor is also recommended to avoid oscillations caused by supply cable inductance or by the Module's built-in capacitors that could lead to a voltage overshoot at power plug-in.

4.1.4 Logic Supply Voltage

The Micro features a logic supply voltage input. Its voltage range is 10...24 V and must be either sourced separately or by the power supply voltage.

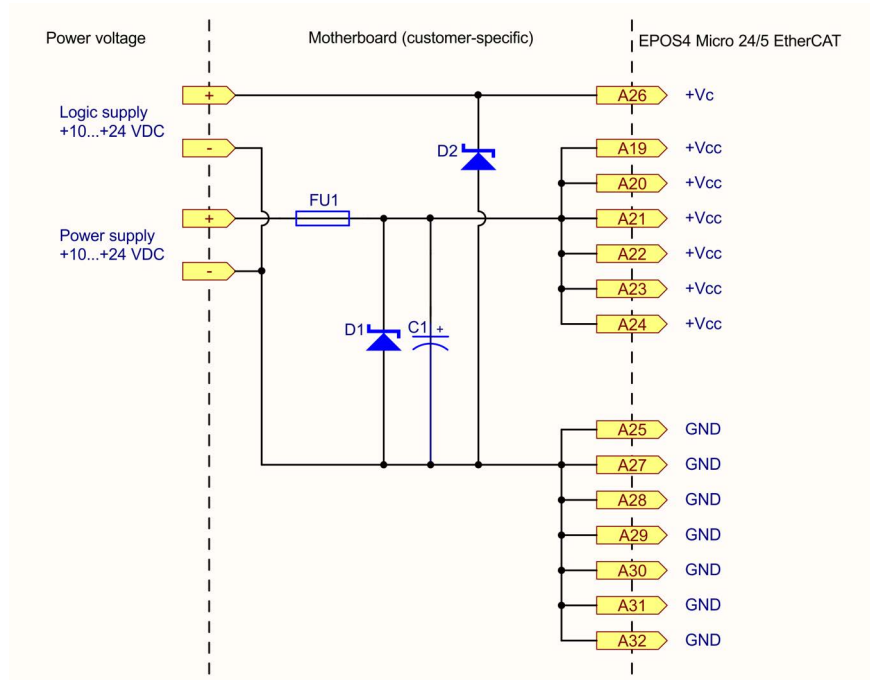

Figure 4-53 Wiring of logic supply

TVS DIODE (D2)

If the logic supply voltage is sourced separately, a transient voltage suppressor diode (D2) at the logic supply voltage input can be connected to protect the Micro against overvoltage.

4.1.5 Motor Cables and Motor Chokes

The Micro is not equipped with internal motor chokes.

The majority of motors and applications do not require additional chokes. However, in case of high supply voltage with very low terminal inductance, the ripple of the motor current can reach an unacceptably high value. This causes the motor to heat up unnecessarily and causes instable control behavior. The minimum terminal inductance required per phase can be calculated using the following formula:

$$L_{Phase} \geq \frac{1}{2} \cdot \left(\frac{V_{CC}}{6 \cdot f_{PWM} \cdot I_N} - (0.3 \cdot L_{Motor}) \right)$$

$L_{Phase}[H]$	Additional external inductance per phase
$V_{CC}[V]$	Operating voltage +V _{CC}
$f_{PWM}[Hz]$	Switching frequency of the power stage = 50'000 Hz
$I_N[A]$	Nominal current of the motor (→line 6 in the maxon catalog)
$L_{Motor}[H]$	Terminal inductance of the motor (→line 11 in the maxon catalog)

If the result of the calculation is negative, no additional chokes are necessary. Nevertheless, the use of chokes in combination with additional filter components can be useful to reduce the emission of electromagnetic interference.

An additional choke must feature electromagnetic shielding, an adequate saturation current, minimal losses, and a nominal current greater than the continuous current of the motor. The below wiring example refers to an additional inductance of 2.2 µH or 15 µH. If a different additional inductance is required, also the filter components must be adapted accordingly. Should you need further help with the filter design, contact maxon Support at →<http://support.maxongroup.com>.

Continued on next page.

Example 1

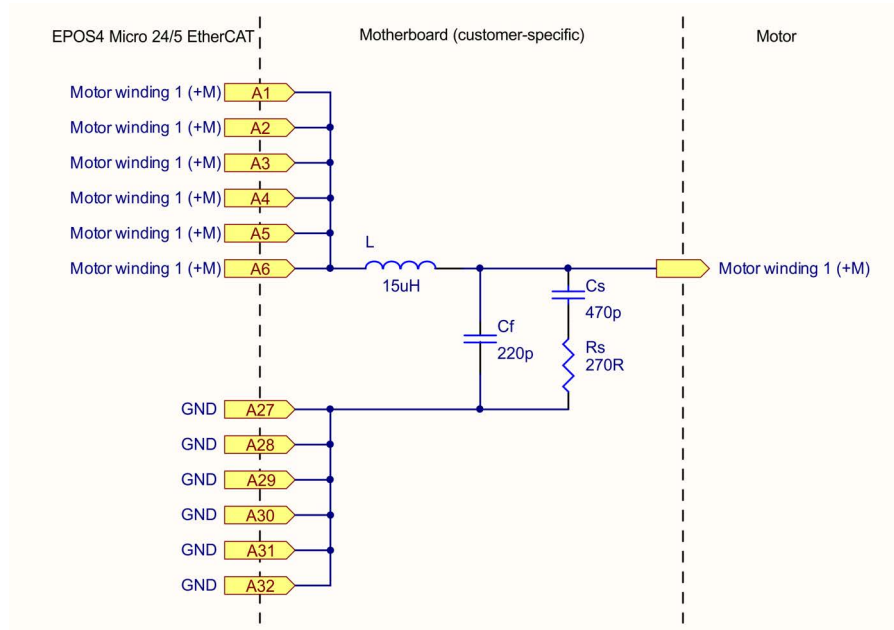

Example 2

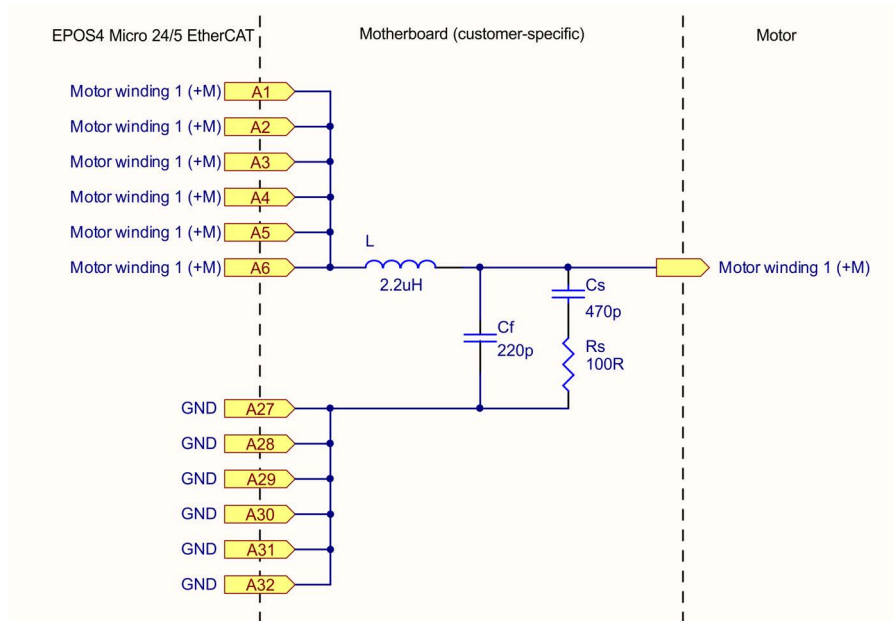

Figure 4-54 Wiring of motor winding 1 (analogously valid also for motor windings 2 & 3)

4.1.6 EIA RS422 Standard for High Speed I/Os and SSI Sensor

If you intend to use an EIA RS422 standard (line driver) for the High Speed I/Os and the SSI sensor, an external RS422 transceiver is necessary.

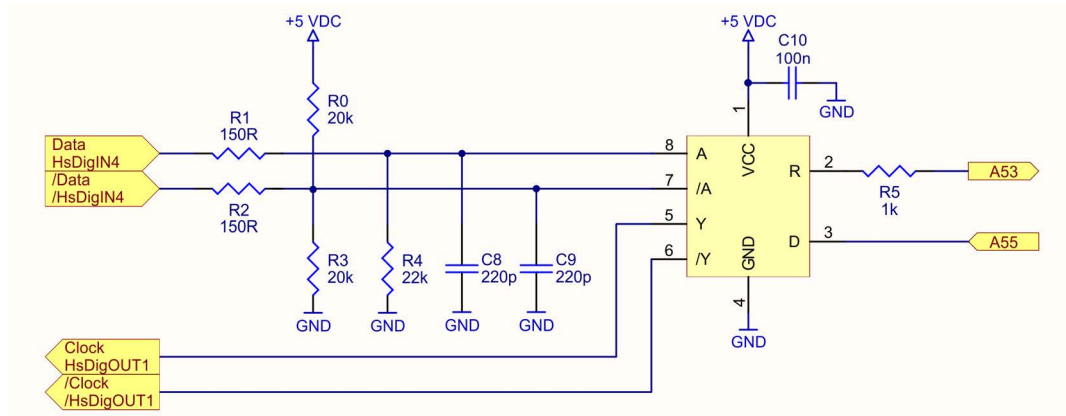

Figure 4-55 Wiring of RS422 transceiver

4.1.7 EtherCAT and Magnetics

The PCB traces that connect the EtherCAT input/outputs to the magnetics (X14/X15), respectively to the next EPOS4 Micro 24/5 EtherCAT via capacitive link must be run as differential pairs. Thereby, the differential impedance should be 100 Ω. You can find freely available “differential stripline impedance calculators” on the Internet that help you calculate the differential impedance.

The following example shows a 2-axes system. Thereby, the internal EtherCAT links are capacitive and the external EtherCAT links are designed with magnetic transformers. The LinkMode input is switched to GND for capacitive coupling and left open for magnetic coupling.

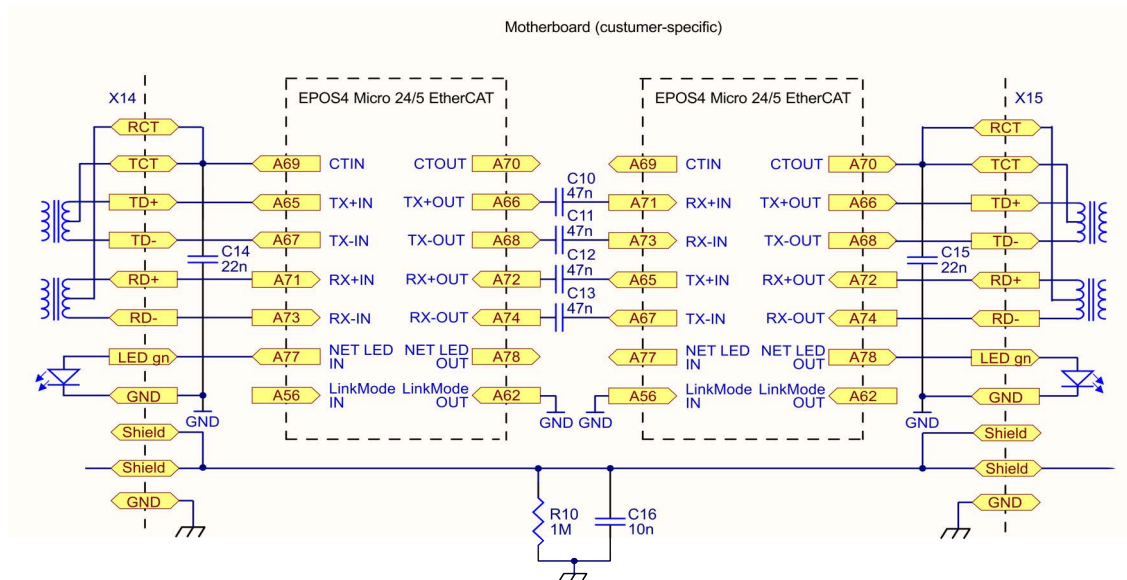

Figure 4-56 Wiring of EtherCAT

4.1.8 LEDs

Besides the physical NET Status LEDs located on the «Micro» (→ Figure 3-51 on page 3-75), four additional outputs are provided to pick up EtherCAT status, errors, and port activity.

4.1.8.1 EtherCAT Status LEDs

Two outputs are provided to display the actual status and possible errors of the EtherCAT network.

LED		Description
Green	Red	
OFF	—	EPOS4 is in state INIT
Blink	—	EPOS4 is in state PRE-OPERATIONAL
Single flash	—	EPOS4 is in state SAFE-OPERATIONAL
ON	—	EPOS4 is in state OPERATIONAL
—	OFF	EPOS4 is in operating condition
—	Double flash	An application watchdog timeout has occurred <i>Example: Timeout of Sync Manager Watchdog</i>
—	Single flash	EPOS4 has changed the COM state due to an internal error <i>Example: Change of state "Op" to "SafeOpError" due to Sync Error</i>
—	Blink	General Configuration Error <i>Example: State change commanded by master is not possible due to actual settings (register, object, hardware configuration)</i>

Blink = continuous blinking (≈2.5 Hz) Flash = Flashing (≈0.2 s), followed by pause of 1 s

Table 4-92 EtherCAT status LEDs

The outputs are designed as open-collector circuit with internal series resistor of 330 Ohm. An external LED can be mounted as long as the current is limited to less than 10 mA with an matching series resistor (Rs).

Red/green EtherCAT status LED "sinks"	
Max. input voltage	+5.5 VDC
Max. load current	10 mA

Table 4-93 EtherCAT status LED "sinks"

Continued on next page.

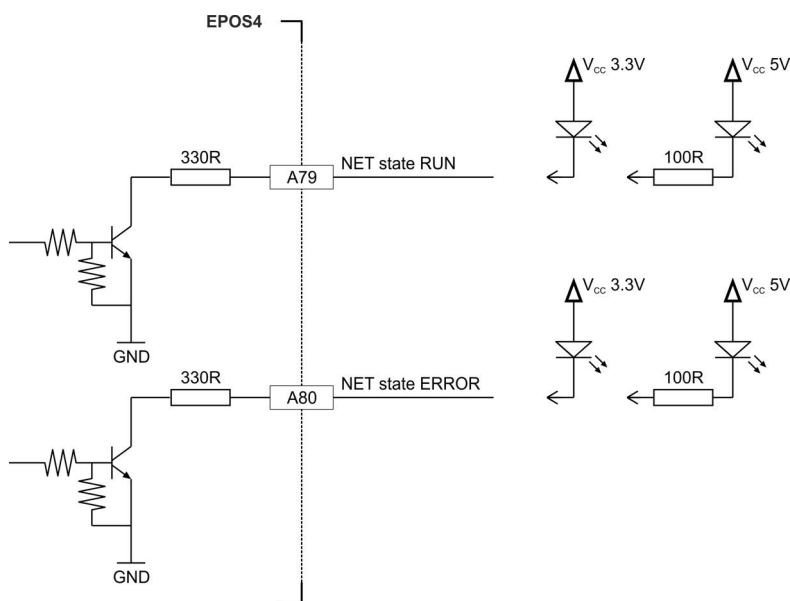

Figure 4-57 EtherCAT status LED "sinks" (analogously valid for B11)

4.1.8.2 EtherCAT Port LEDs

Two outputs are provided to display the EtherCAT port's link activity (applies for both ports "EtherCAT IN" and "EtherCAT OUT").

LED Green	Description
OFF	Port is closed
Flicker	Port is open / activity is present
ON	Port is open
—	Data rate is 100 Mbit/s
Flicker = Continuous flickering (≈ 10 Hz)	

Table 4-94 EtherCAT port LEDs

The outputs are designed to drive integrated LEDs of standard modular port jacks according the following specification:

Green EtherCAT port activity LED "source"	
Output voltage	$U_{Out} = 3.3\text{ V} - (I_{Load} \times 150\ \Omega)$
Max. load current	10 mA

Table 4-95 EtherCAT port activity LED "source"

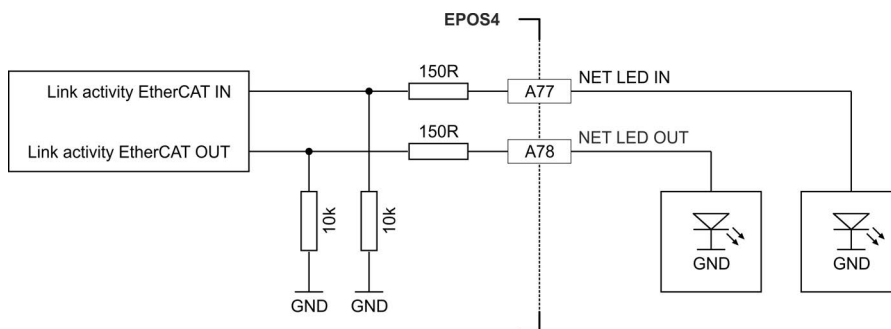

Figure 4-58 EtherCAT port activity LED "source"

4.1.9 ESD Protection

The Module does not feature its own ESD protection circuitry. ESD protection must be provided by the motherboard that holds the USB port to which the protective circuitry must be located as close as possible.

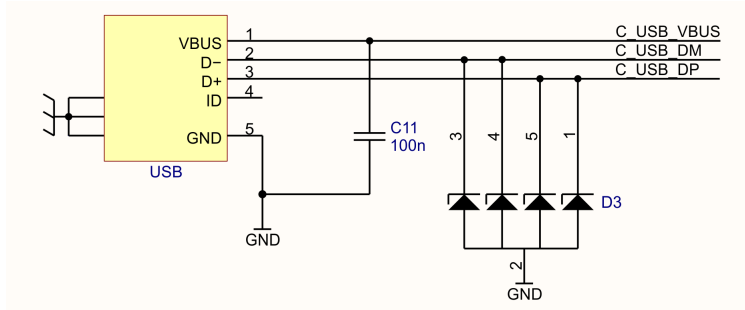

Figure 4-59 USB protection circuitry

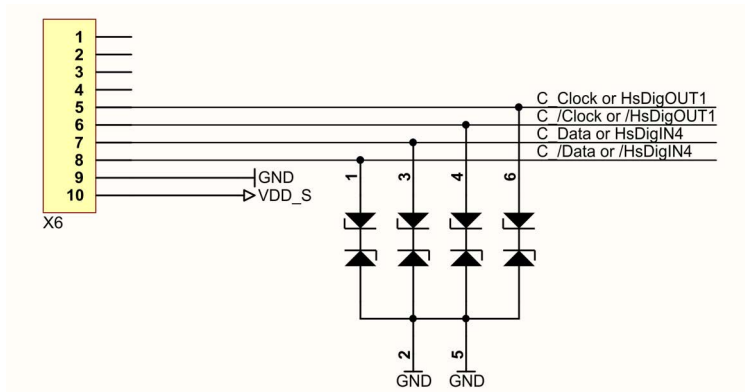

Figure 4-60 High-speed digital input/output and sensor protection circuitry

4.1.10 Recommended Components and Manufacturers

Recommended components	
Terminal/socket strip	Dual row terminal/socket combo strip, 0.5 mm pitch 40 poles, 2 rows: • maxon (677324) • Samtec (LSHM-140-02.5-L-DV-A-N-K-TR)
Spacer	2 spacers Ø4.3 x 5 mm, M2 thread • Würth (9774050243) (9774050243R)
Fuse (FU1)	• Littelfuse 157 Series, Fuse 10 A, 26.46 A ² sec (0157010)
TVS Diode (D1; D2)	<ul style="list-style-type: none"> • Vishay SMF30A $U_R = 30 \text{ V}, U_{BR} = 33.3 \dots 36.8 \text{ V @ } 1 \text{ mA}, U_C = 48.4 \text{ V @ } 4.1 \text{ A}$ • Littelfuse SMF30A $U_R = 30 \text{ V}, U_{BR} = 33.3 \dots 36.8 \text{ V @ } 1 \text{ mA}, U_C = 48.4 \text{ V @ } 4.1 \text{ A}$ • NXP PTVS30VS1UR $U_R = 30 \text{ V}, U_{BR} = 33.3 \dots 36.8 \text{ V @ } 1 \text{ mA}, U_C = 48.4 \text{ V @ } 8.3 \text{ A}$
Capacitor (C1)	<p>The ripple current load for C1 depends on the motor's operating point and the power supply output capacity. Under worst case conditions however, the ripple current may reach $I_{cont} / 2$. Use capacitors with rated voltage $\geq 35 \text{ V}$ and adequate ripple current to avoid overheat or life time reduction.</p> <p>Remark: If there is an excessive amount of reversed energy present (for example during deceleration of loads with a high inertia or during a vertical movement downwards), there might be the need to add an additional capacitor with a much higher capacitance (for example up to 10'000...47'000 μF) and/or to add a brake chopper, for example maxon DSR 70/30 (235811).</p> <p>Example for C1 worst-case dimensioning: $I_{cont} = 5 \text{ A} \rightarrow$ Nippon Chemicon (HHXB350ARA680MF80G) / Panasonic (EEHZA1V680XP); 68 μF, 35 V, 1990 mA r.m.s.</p>
Motor Choke (L)	<p>Inductance: → "Motor Cables and Motor Chokes" on page 4-82 Rated current: $I_{rms} \geq I_{cont}; I_{sat} \geq I_{peak}$ Construction: shielded</p> <p>15 μH: • Würth (WE-PD-XXL / 7447709150) $I_{rms} 6.5 \text{ A}, I_{sat} 8.0 \text{ A}, 12 \times 12 \times 10 \text{ mm}$</p> <p>2.2 μH: • Bourns (SRP7028A-2R2M) $I_{rms} 8 \text{ A}, I_{sat} 14 \text{ A}, 7.3 \times 6.6 \times 2.8 \text{ mm}$ • Eaton (HCM0703-2R2-R) $I_{rms} 8 \text{ A}, I_{sat} 14 \text{ A}, 7.1 \times 6.6 \times 3 \text{ mm}$ • Würth (744311220) $I_{rms} 9 \text{ A}, I_{sat} 13 \text{ A}, 7 \times 6.9 \times 3.8 \text{ mm}$</p>
Motor Filter	<p>Example 1</p> <ul style="list-style-type: none"> • Motor Choke L 15 μH • Filter Capacitor Cf 220 pF, 100 V • Snubber Capacitor Cs 470 pF, 100 V • Snubber Resistor Rs 270 Ω, 0.25 W <p>Example 2</p> <ul style="list-style-type: none"> • Motor Choke L 2.2 μH • Filter Capacitor Cf 220 pF, 100 V • Snubber Capacitor Cs 470 pF, 100 V • Snubber Resistor Rs 100 Ω, 0.25 W

Continued on next page.

Recommended components		
RS422 (IC2) (C8...C10) (R0...R4)	RS422 transceiver (IC2)	Renesas/Intersil (ISL8490EIBZ-T)
	Capacitors (C8; C9)	220 pF, COG/NPO, 50 V
	Capacitor (C10)	100 nF, X6S/X7R, 16 V
	Resistors (R0; R3)	20 kΩ, 0.063W
	Resistors (R1; R2)	150 Ω, 0.063W
	Resistor (R4)	22 kΩ, 0.063 W
EtherCAT RJ45 plug (X14; X15) (C10...C16) (R10)	RJ45 plug (X14; X15)	<ul style="list-style-type: none"> • 1 Port RJ45 Magnetic Jack (SI-46014-F, 74990101241, JXD2-0010NL) • 2 Port RJ45 Magjack Connector (JXD0-2005NL, SI-60159-F, ARJ12A-MASD-A-B-EM02)
	Capacitors (C10...C13)	47 nF, X6S/X7R, 50 V
	Capacitors (C14; C15)	22 nF, X6S/X7R, 50 V
	Capacitor (C16)	10 nF, X6S/X7R, 500 V
	Resistor (R10)	1 MΩ, 0.25 W, 500 V
TVS Diode (D3) (C11)	TVS diode (D3) <ul style="list-style-type: none"> • Nexperia PESD5V0L4UG • ST ESDALC6V1W5 	$U_{BR} = 6.46...7.14 \text{ V @ } 1 \text{ mA}$, $V_C = 13 \text{ V @ } 2.5 \text{ A}$ $U_{BR} = 6.46...7.2 \text{ V @ } 1 \text{ mA}$
	Capacitor (C11)	100 nF, X7R, 16 V

Table 4-96 Motherboard Design Guide – Recommended components

4.2 Design Guidelines

The following instructions are intended to serve as an aid when designing an application-specific motherboard and ensures the correct and reliable integration of the Micro.

While designing a motherboard, consider the following characteristics of the Micro:

- Pin assignment (→page 3-22)
- Technical data (→page 2-11) and dimensional drawing (→page 2-17)

4.2.1 Ground

All ground connections (GND) should be internally connected to the Micro (equal potential). It is customary to equip the motherboard with a ground plane. All ground connections should be connected to the voltage supply ground via wide conductive tracks.

Pin	Signal	Description
A25	GND	Ground
A27...A32	GND	Ground
A57...A58	GND	Ground
A63...A64	GND	Ground
A75...A76	GND	Ground
Mounting holes	GND	Ground connections for spacers

Table 4-97 Motherboard Design Guide – Grounding

If an earth potential is in place or required, the ground plane should be connected to the earth potential via one or more capacitors. The use of ceramic capacitors with 100 nF and 100 V is recommended.

4.2.2 Layout

Guidelines for the layout of the motherboard:

- Connector pins [A19...A24] for +V_{CC} (nominal power supply voltage) should be connected to the fuse via wide conductive tracks.
- Connector pins [A25], [A27...A32], [A57], [A58], [A63], [A64], [A75], and [A76] for GND (ground) should be connected with the operating voltage ground via wide conductive tracks.
- The width of the conductive tracks and the copper coating thickness of the conductors for supply voltage and motor depend on the current required in your application. A minimum track width of 75 mil and a minimum copper coating thickness of 35 µm are recommended.

4.3 Terminal/Socket Placement & SMT Footprint

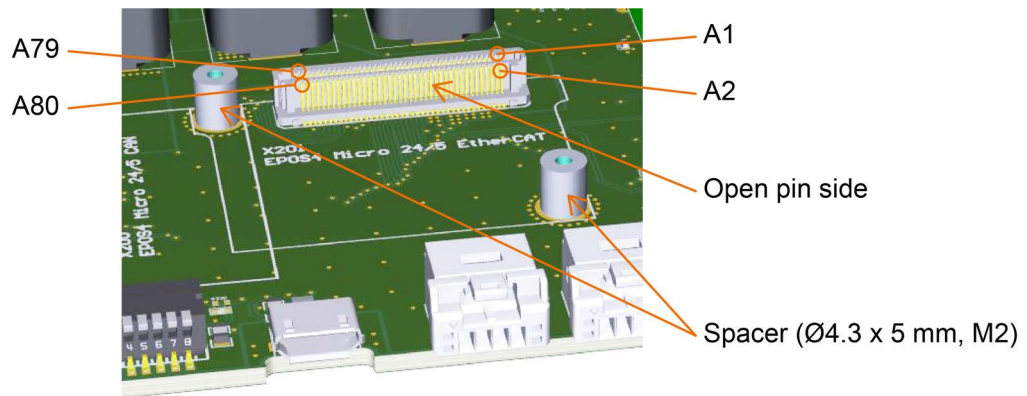

Figure 4-61 EPOS4 Micro 24/5 EtherCAT – Terminal/socket placement (example)



Mirroring of terminal rows

The socket is of hermaphroditic design. When mating the Module's socket onto the motherboard's socket, you must consider to mirror the pinning of the motherboard's socket (→Figure 4-62, left, blue shaded).

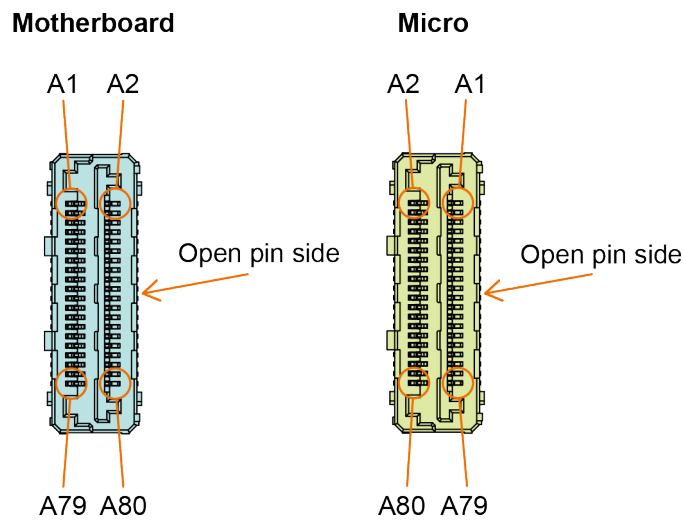

Figure 4-62 EPOS4 Micro 24/5 EtherCAT – Terminal/socket placement (mating)



Possible dimensional differences in STEP files

For conversion reasons, the below stated dimensions may slightly differ from the dimensions specified in the downloadable STEP file. Use only the below stated dimensions for your design.

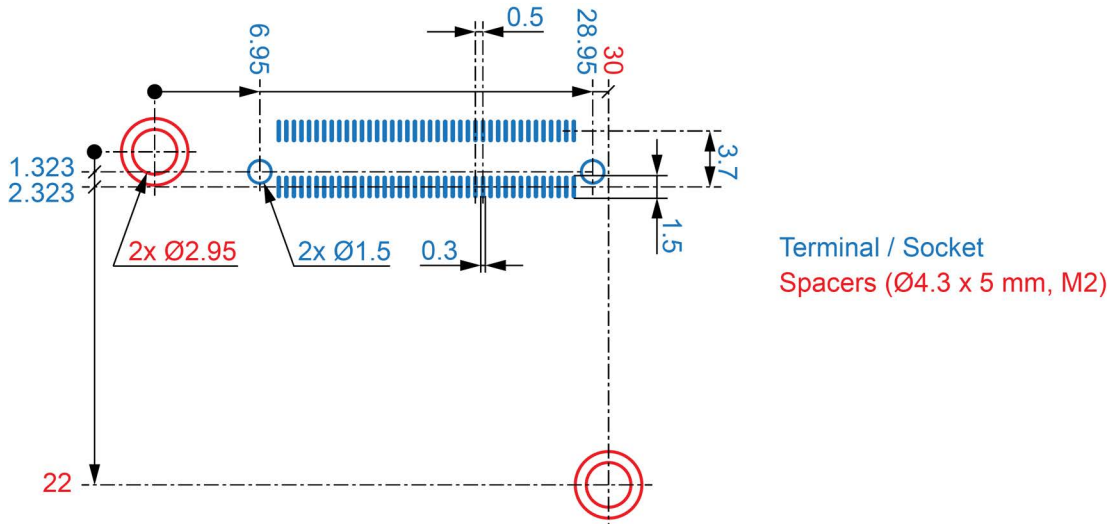

Figure 4-63 EPOS4 Micro 24/5 EtherCAT– Terminal/socket footprint

5 WIRING

In this section you will find the wiring information for the setup you are using. You can either use the consolidated wiring diagrams featuring the full scope of interconnectivity and pin assignment. Or you may wish to use the connection overviews for either DC motor or EC (BLDC) motor that will assist you in determining the wiring for your particular motor type and the appropriate feedback signals.

The «MoBo» and «Compact» can host up to three «Micro» modules and are therefore ready to drive one, two, or three axes. Thereby, the power supply, logic supply, and EtherCAT interface for all axes are each merged in one consolidated connector. The axis-specific wiring is separately connected for up to three individual axes.

The connectors on the PCBs are marked as to the following → Table 5-98. Take note that in the subsequent diagrams the designation of the axis 1, 2, and 3 is omitted (respective connectors marked in **blue color**).

EvaBo	MoBo / Compact			In wiring diagrams
	Axis 1	Axis 2	Axis 3	
X1	X1	X1	X1	X1
X2	X2	X2	X2	X2
X3	X3_1	X3_2	X3_3	X3
X4	X4_1	X4_2	X4_3	X4
X5	—	—	—	X5
—	X5/X6_1	X5/X6_2	X5/X6_3	X5/X6
X6	—	—	—	X6
X7	X7_1	X7_2	X7_3	X7
X8	X8_1	X8_2	X8_3	X8
X13	X13_1	X13_2	X13_3	X13
X14	X14	X14	X14	X14
X15	X15	X15	X15	X15

Table 5-98 Designation of connectors and PCB marking



Signs and abbreviations used

The subsequent diagrams feature these signs and abbreviations:

- «EC Motor» stands for brushless EC motor (BLDC).
-  Ground safety earth connection (optional).

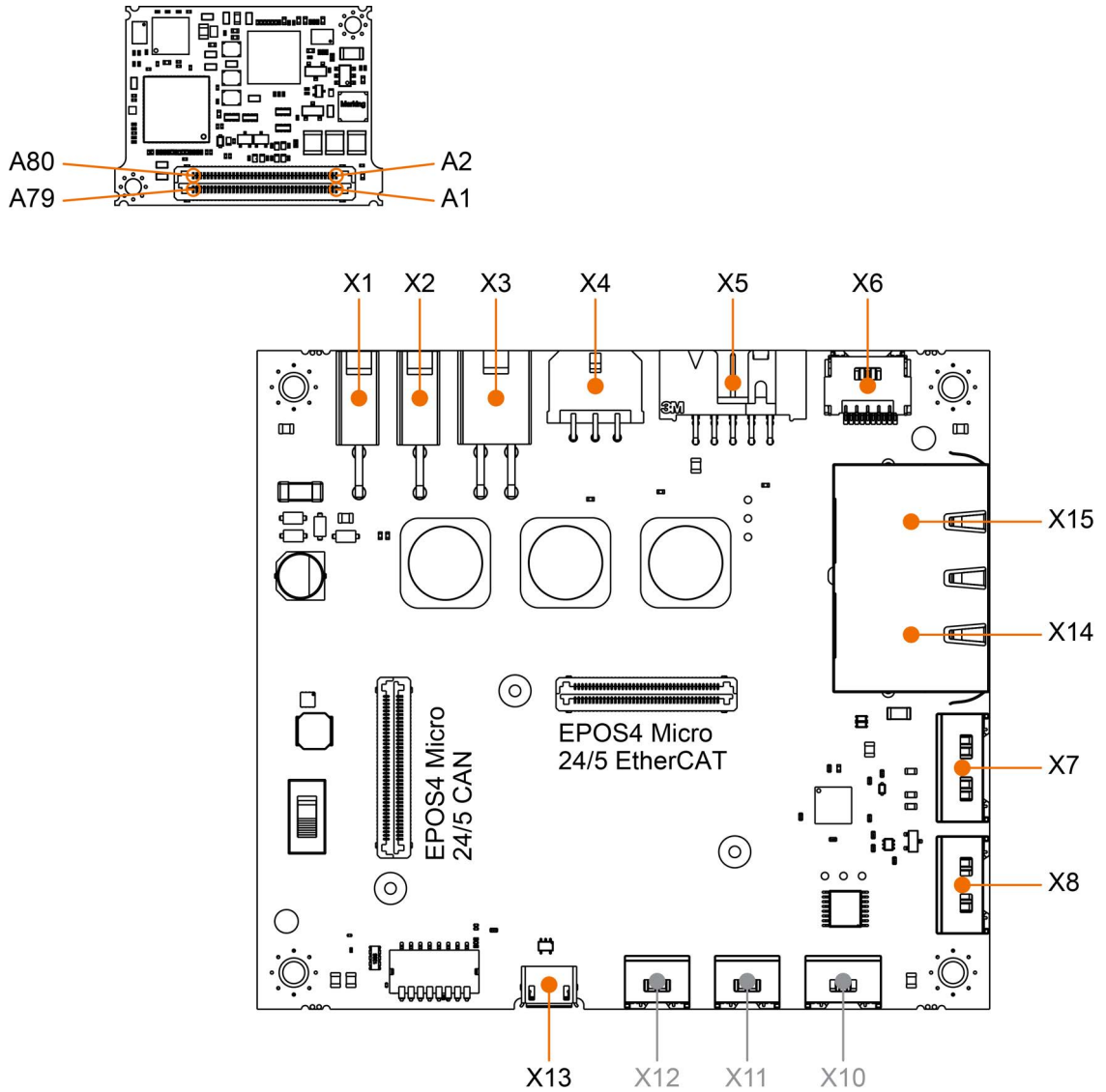

Figure 5-64 Interfaces – Designations and location Micro & EvaBo

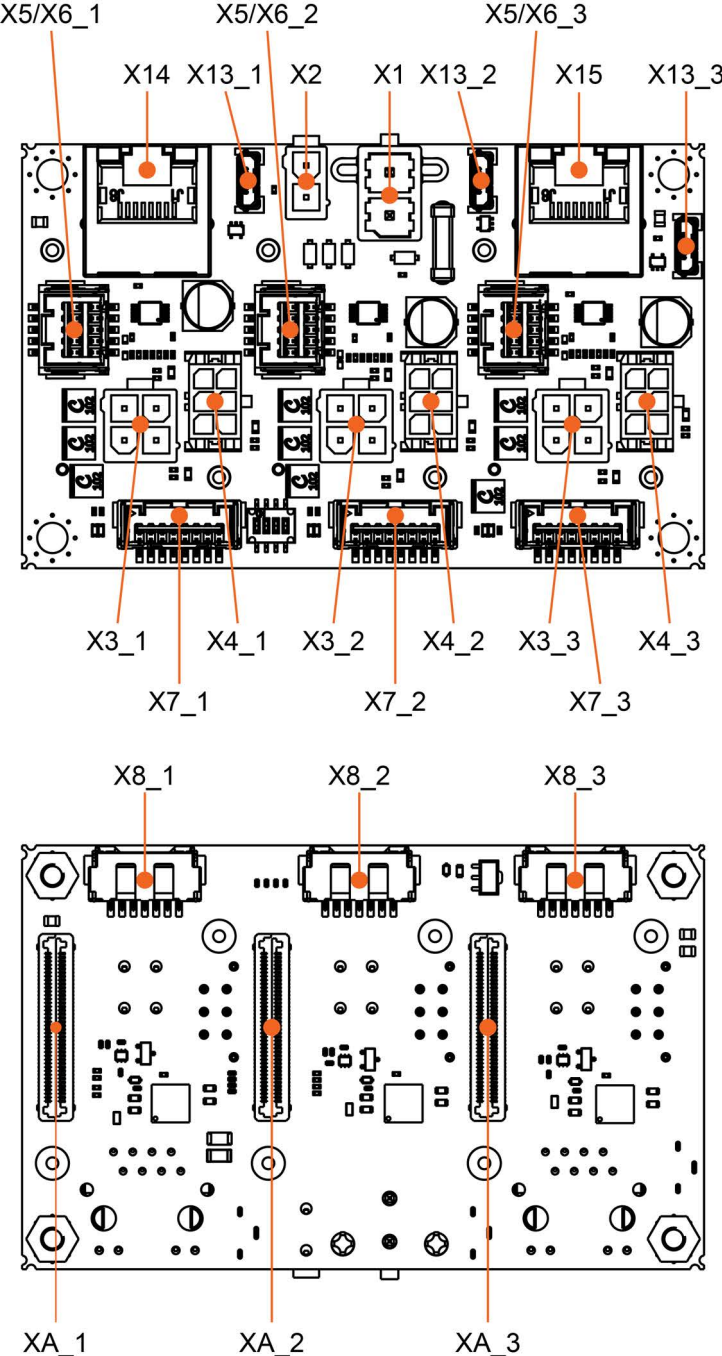

Figure 5-65 Interfaces – Designations and location Micro & MoBo & Compact

5.1 Possible Combinations to connect a Motor

The following tables show feasible ways on how to connect the motor with its respective feedback signals or possible combinations thereof. To find the wiring that best suits your setup, proceed as follows:

- 1) Decide on the type of motor you are using; either DC or EC (BLDC) motor.
- 2) Connect the power supply and the logic supply by following the link to the stated figure.
- 3) Check-out the listing for the combination that best suits your setup. Pick the wiring method # and go to the respective table; for DC motor → Table 5-99, for EC (BLDC) motor → Table 5-100.
- 4) Pick the row with the corresponding wiring method # and follow the link (or links) to the stated figure(s) to find the relevant wiring information.

5.1.1 DC Motor

Power supply & optional logic supply Figure 5-68

Motor & feedback signals

Without sensor Method # DC1
 Digital incremental encoder Method # DC2
 SSI absolute encoder Method # DC5
 Digital incremental encoder & SSI absolute encoder Method # DC8

Method #	Digital Incremental Encoder 1 (Sensor 1) X5	SSI Absolute Encoder (Sensor 2) X6	→Figure(s)
DC1			5-69
DC2	✓		5-69 5-72
DC5		✓	5-69 5-73
DC8	✓	✓	5-69 5-72 / 5-73

Table 5-99 Possible combinations of feedback signals for DC motor

5.1.2 EC (BLDC) Motor

Power supply & optional logic supply Figure 5-68

Motor & feedback signals

Hall sensors Method # EC1

Hall sensors & Digital incremental encoder Method # EC2

Hall sensors & SSI absolute encoder Method # EC5

Hall sensors & Digital incremental encoder & SSI absolute encoder Method # EC8

Digital incremental encoder & SSI absolute encoder Method # EC9

SSI absolute encoder Method # EC10

Method #	Hall sensors (Sensor 3) X4	Digital Incremental Encoder 1 (Sensor 1) X5	SSI Absolute Encoder (Sensor 2) X6	→Figure(s)
EC1	✓			5-70 5-71
EC2	✓	✓		5-70 5-71 / 5-72
EC5	✓		✓	5-70 5-71 / 5-73
EC8	✓	✓	✓	5-70 5-71 / 5-72 / 5-73
EC9		✓	✓	5-70 5-72 / 5-73
EC10			✓	5-70 5-73

Table 5-100 Possible combinations of feedback signals for EC (BLDC) motor

5.2 Main Wiring Diagrams

5.2.1 Micro & EvaBo

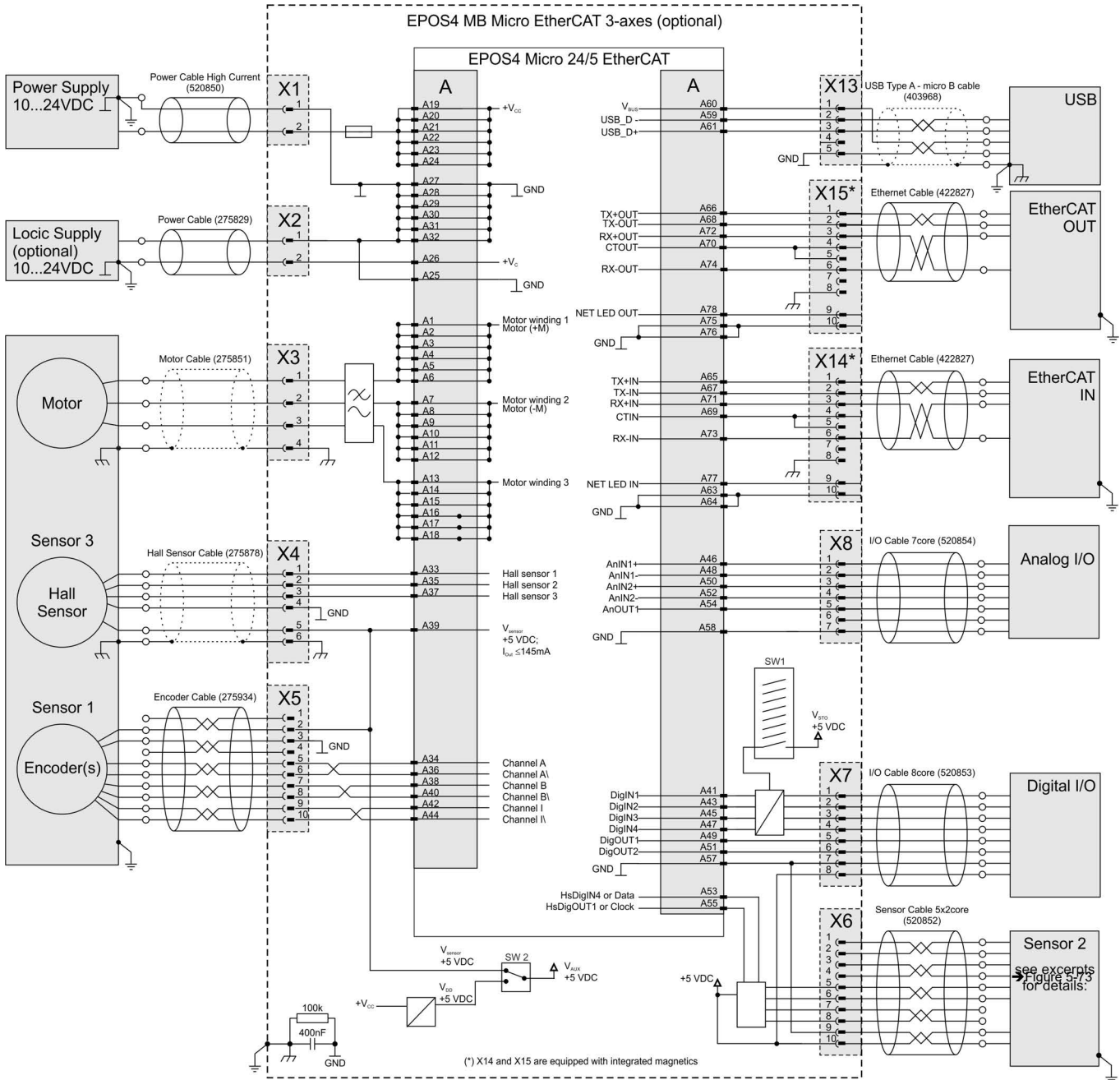

Figure 5-66 Main wiring diagram – Micro & EvaBo

5.2.2 Micro & MoBo / Compact



Operation of up to three axis

With «MoBo» and «Compact», up to three individually connected axes can be operated. For easier legibility, the respective connectors are indicated just once. For example «X3» stands for the connector X3_1, X3_2, and X3_3 of the respective axis.

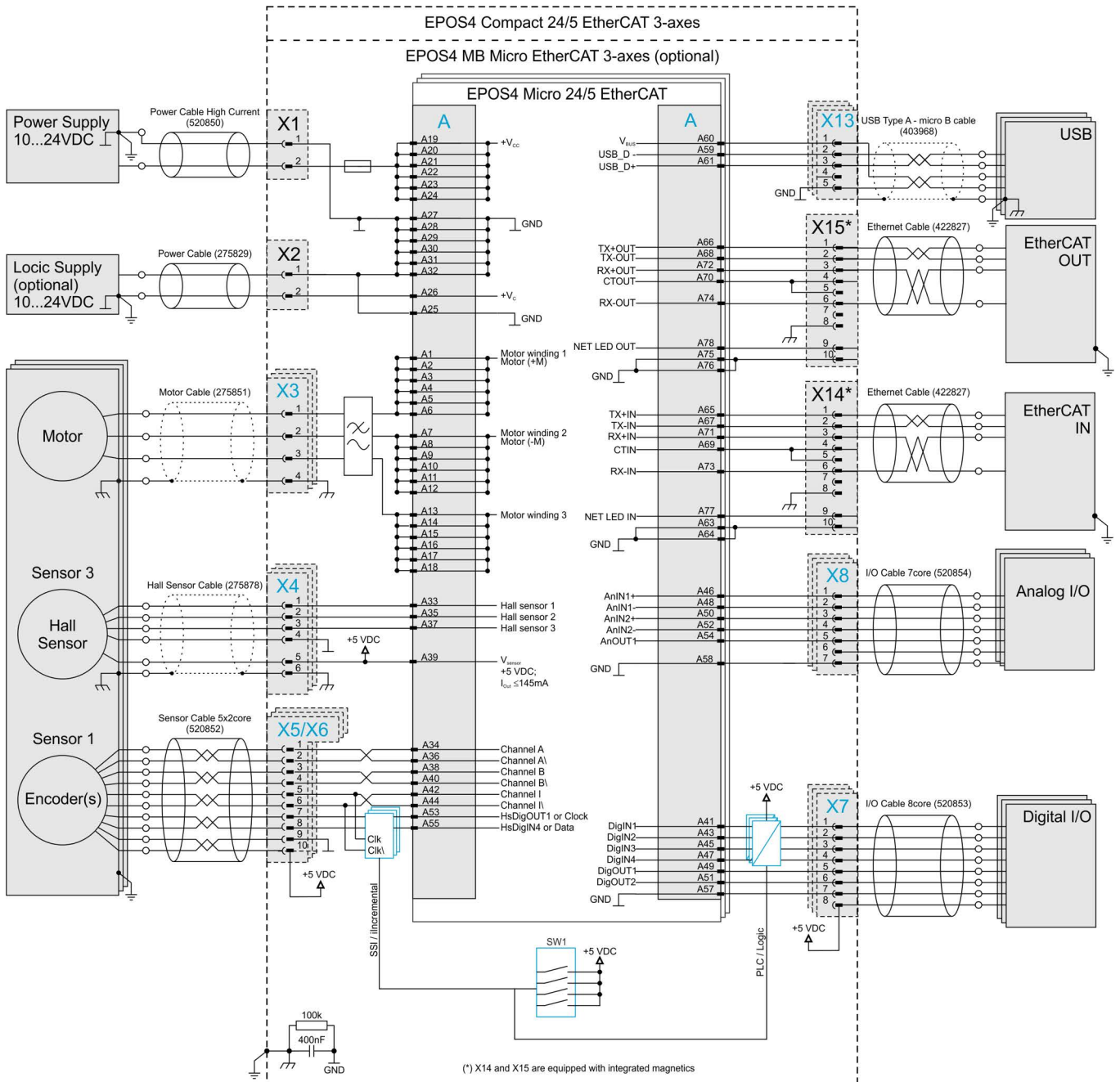

Figure 5-67 Main wiring diagram – Micro & MoBo / Compact

5.3 Excerpts



Operation of up to three axis

With «MoBo» and «Compact», up to three individually connected axes can be operated. For easier legibility, the respective connectors are indicated just once. For example “X3” stands for the connector X3_1, X3_2, and X3_3 of the respective axis.

5.3.1 Power & Logic Supply

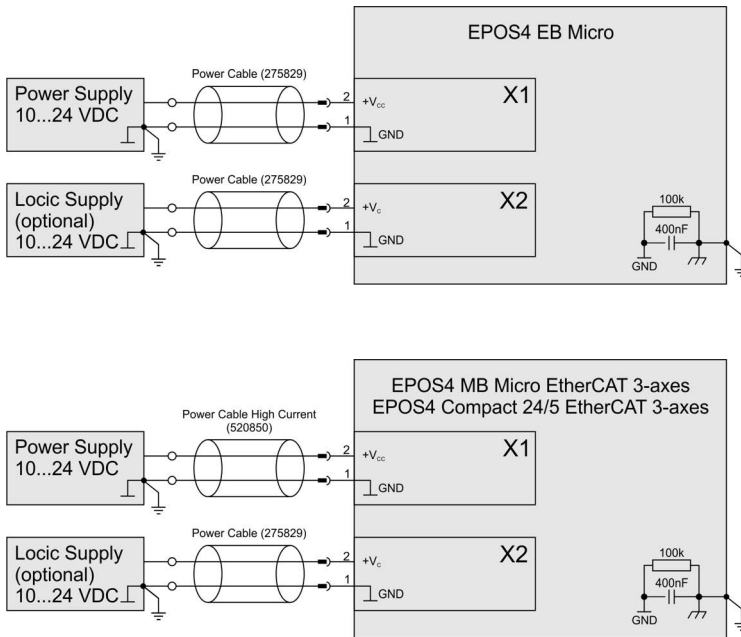

Figure 5-68 Power & logic supply

5.3.2 DC Motor

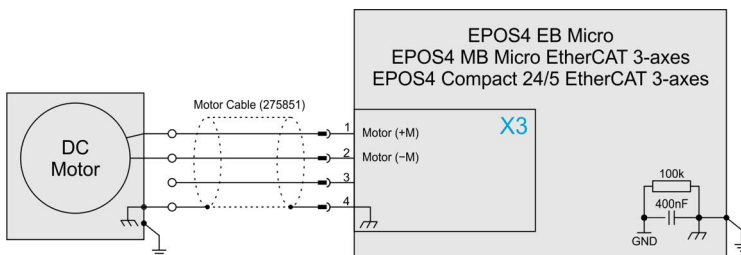

Figure 5-69 DC motor

5.3.3 EC (BLDC) Motor

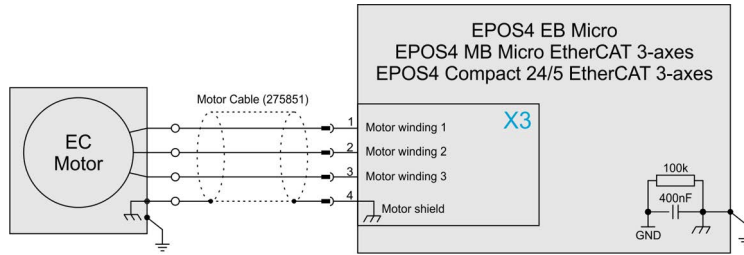

Figure 5-70 EC (BLDC) motor

5.3.4 Hall Sensors (Sensor 3)

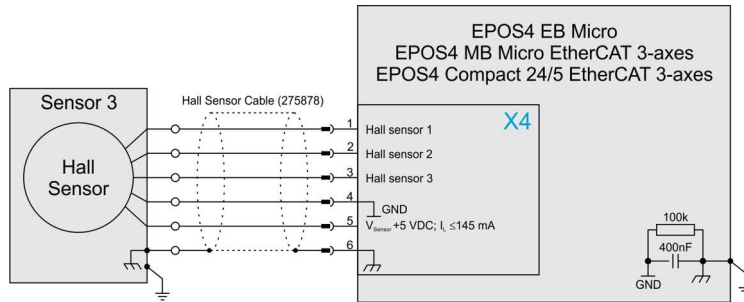

Figure 5-71 Hall sensors (Sensor 3)

5.3.5 Digital Incremental Encoder 1 (Sensor 1) on X5

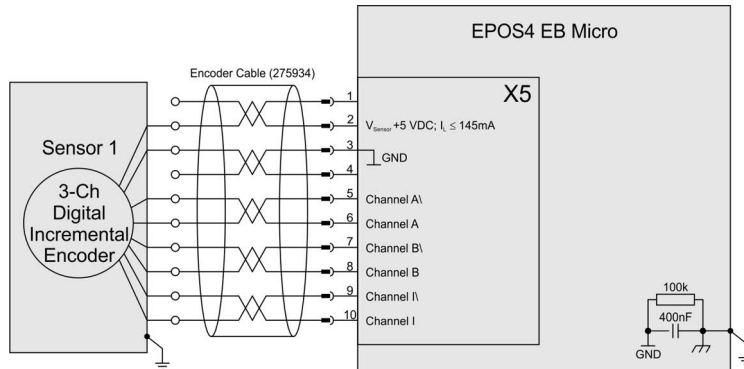

Figure 5-72 Digital incremental encoder 1 (Sensor 1) on X5

5.3.6 SSI Encoder (Sensor 2) on X6

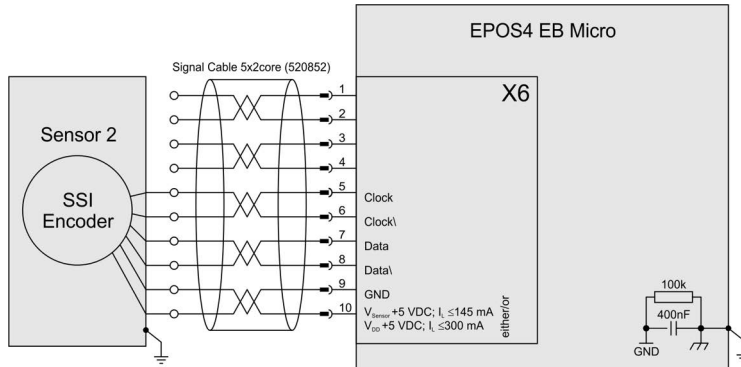

Figure 5-73 SSI encoder (Sensor 2) on X6

5.3.7 Digital Incremental Encoder 1 (Sensor 1) on X5/X6

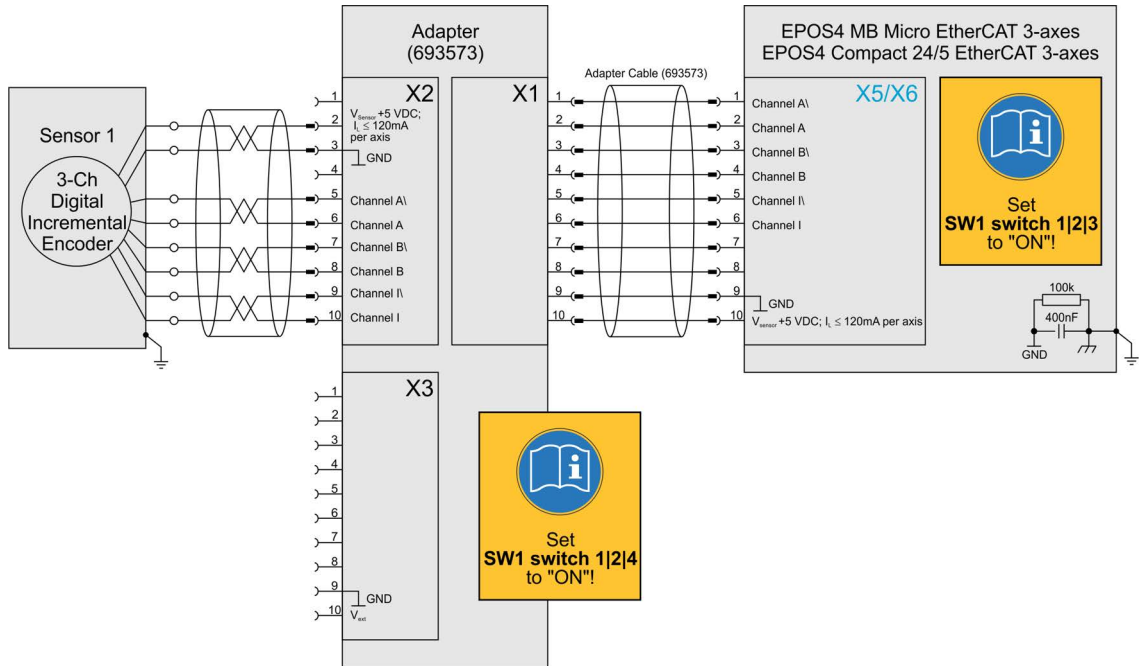

Figure 5-74 Digital incremental encoder 1 (Sensor 1) on X5/X6

5.3.8 SSI Encoder (Sensor 2) on X5/X6

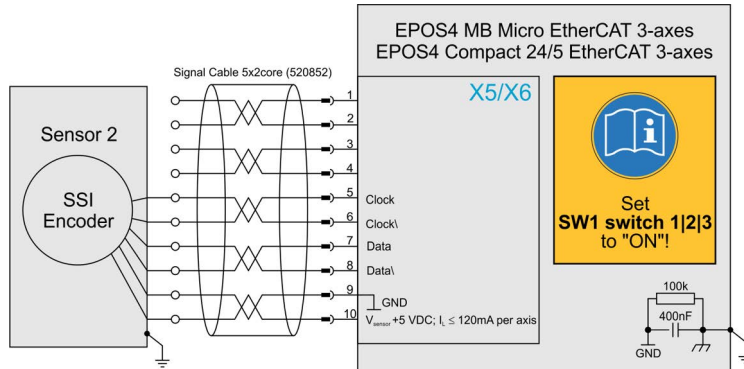

Figure 5-75 SSI encoder (Sensor 2) on X5/X6

5.3.9 Digital Incremental Encoder (Sensor 1) and SSI Encoder (Sensor 2) on X5/X6

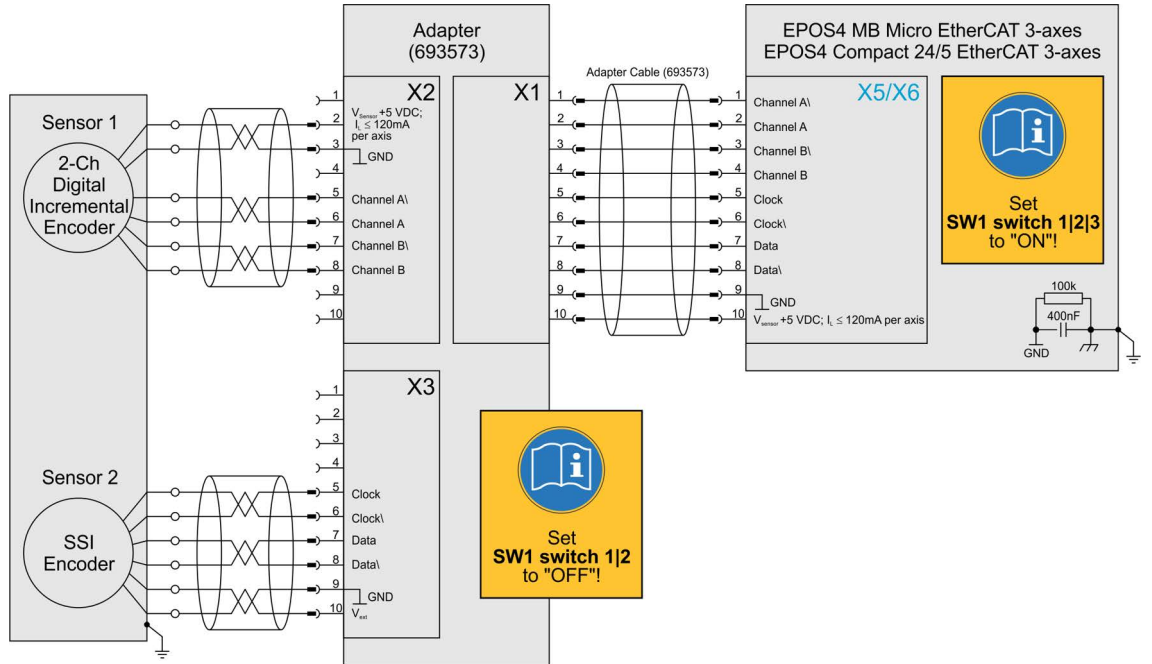

Figure 5-76 Digital incremental encoder (Sensor 1) and SSI encoder (Sensor 2) on X5/X6

••page intentionally left blank••

LIST OF FIGURES

Figure 1-1	Documentation structure	5
Figure 2-2	Derating of output current – Micro.	14
Figure 2-3	Derating of output current – Compact	15
Figure 2-4	Power dissipation and efficiency – EPOS4 Micro 24/5 EtherCAT.	16
Figure 2-5	EPOS4 Micro 24/5 EtherCAT – Dimensional drawing [mm].	17
Figure 2-6	EPOS4 EB Micro – Dimensional drawing [mm]	17
Figure 2-7	EPOS4 MB Micro EtherCAT 3-axes / EPOS4 Compact 24/5 EtherCAT 3-axes – Dimensional drawing [mm] 18	
Figure 3-8	Pin assignment	22
Figure 3-9	EPOS4 EB Micro (without/with EPOS4 Micro 24/5 EtherCAT).	24
Figure 3-10	Connector Boards – Connectors	26
Figure 3-11	Power supply connector X1.	27
Figure 3-12	Logic supply connector X2	27
Figure 3-13	Motor connectors X3	28
Figure 3-14	Hall sensor connector X4	29
Figure 3-15	Encoder connector X5.	29
Figure 3-16	Sensor connector X6.	30
Figure 3-17	Digital I/O connector X7	31
Figure 3-18	Analog I/O connector X8	31
Figure 3-19	USB connector X13.	32
Figure 3-20	EtherCAT IN connector X14 & EtherCAT OUT connectorX15	33
Figure 3-21	EvaBo switches – Location	34
Figure 3-22	EPOS4 MB Micro EtherCAT 3-axes (top view/bottom view).	36
Figure 3-23	EPOS4 Compact 24/5 EtherCAT 3-axes (top view/bottom view)	36
Figure 3-24	EPOS4 MB Micro EtherCAT 3-axes & EPOS4 Compact 24/5 EtherCAT 3-axes – Connectors.	39
Figure 3-25	Power supply connector X1.	40
Figure 3-26	Logic supply connector X2	40
Figure 3-27	Motor connectors X3_1 / X3_2 / X3_3	41
Figure 3-28	Hall sensor connector X4_1 / X4_2 / X4_3	42
Figure 3-29	Encoder/Sensor combo connector X5/X6_1 / X5/X6_2 / X5/X6_3	43
Figure 3-30	Digital I/O connector X7_1 / X7_2 / X7_3	44
Figure 3-31	Analog I/O connector X8_1 / X8_2 / X8_3	45
Figure 3-32	USB connector X13_1 / X13_2 / X13_3	46
Figure 3-33	EtherCAT IN connector X14 & EtherCAT OUT connectorX15	47
Figure 3-34	MoBo/Compact DIP switch SW1 – Location.	48
Figure 3-35	Hall sensor 1 input circuit (analogously valid for Hall sensors 2 & 3 and all axis).	53
Figure 3-36	Encoder input circuit Ch A “differential” (analogously valid for Ch B & Ch I and all axis)	55
Figure 3-37	Encoder input circuit Ch A “single-ended” (analogously valid for Ch B & Ch I and all axis)	56
Figure 3-38	SSI absolute encoder data input	58
Figure 3-39	SSI absolute encoder clock output	59
Figure 3-40	HsDigIN4 circuit “differential”.	60
Figure 3-41	HsDigIN4 circuit “single-ended”.	61

Figure 3-42	HsDigOUT1 output circuit	62
Figure 3-43	DigIN1 circuit (analogously valid for DigIN2...4) – Micro	63
Figure 3-44	DigIN1 circuit (analogously valid for DigIN2...4) – EvaBo & MoBo / Logic level setting	64
Figure 3-45	DigIN1 circuit (analogously valid for DigIN2...4) – EvaBo & MoBo / PLC level setting	65
Figure 3-46	DigOUT1 circuit (analogously valid for DigOUT2)	66
Figure 3-47	DigOUT1 “sinks” (analogously valid for DigOUT2 and EvaBo & MoBo)	67
Figure 3-48	DigOUT1 “source” (analogously valid for DigOUT2 and EvaBo & MoBo)	67
Figure 3-49	AnIN1 circuit (analogously valid for AnIN2)	68
Figure 3-50	AnOUT1 circuit	69
Figure 3-51	LEDs – Location	75
Figure 4-52	Wiring of power supply	80
Figure 4-53	Wiring of logic supply	81
Figure 4-54	Wiring of motor winding 1 (analogously valid also for motor windings 2 & 3)	83
Figure 4-55	Wiring of RS422 transceiver	84
Figure 4-56	Wiring of EtherCAT	84
Figure 4-57	EtherCAT status LED “sinks” (analogously valid for B11)	85
Figure 4-58	EtherCAT port activity LED “source”	86
Figure 4-59	USB protection circuitry	87
Figure 4-60	High-speed digital input/output and sensor protection circuitry	87
Figure 4-61	EPOS4 Micro 24/5 EtherCAT – Terminal/socket placement (example)	91
Figure 4-62	EPOS4 Micro 24/5 EtherCAT – Terminal/socket placement (mating)	91
Figure 4-63	EPOS4 Micro 24/5 EtherCAT– Terminal/socket footprint	92
Figure 5-64	Interfaces – Designations and location Micro & EvaBo	94
Figure 5-65	Interfaces – Designations and location Micro & MoBo & Compact	95
Figure 5-66	Main wiring diagram – Micro & EvaBo	98
Figure 5-67	Main wiring diagram – Micro & MoBo / Compact	99
Figure 5-68	Power & logic supply	100
Figure 5-69	DC motor	100
Figure 5-70	EC (BLDC) motor	101
Figure 5-71	Hall sensors (Sensor 3)	101
Figure 5-72	Digital incremental encoder 1 (Sensor 1) on X5	101
Figure 5-73	SSI encoder (Sensor 2) on X6	102
Figure 5-74	Digital incremental encoder 1 (Sensor 1) on X5/X6	102
Figure 5-75	SSI encoder (Sensor 2) on X5/X6	103
Figure 5-76	Digital incremental encoder (Sensor 1) and SSI encoder (Sensor 2) on X5/X6	103

LIST OF TABLES

Table 1-1	Notation used	6
Table 1-2	Symbols and signs	6
Table 1-3	Brand names and trademark owners	7
Table 1-4	Abbreviations	8
Table 2-5	Technical data	13
Table 2-6	Limitations	16
Table 2-7	Standards	19
Table 3-8	Pin assignment A1...A80	23
Table 3-9	Prefab maxon cables	24
Table 3-10	EPOS4 Connector Set – Content	25
Table 3-11	Recommended tools	25
Table 3-12	Power supply connector X1 – Pin assignment	27
Table 3-13	Logic supply connector X2 – Pin assignment	27
Table 3-14	Motor connector X3 – Pin assignment for maxon DC motor	28
Table 3-15	Motor connector X3 – Pin assignment for maxon EC motor	28
Table 3-16	Hall sensor connector X4 – Pin assignment	29
Table 3-17	Encoder connector X5 – Pin assignment	29
Table 3-18	Encoder connector X5 – Accessories	30
Table 3-19	Sensor connector X6 – Pin assignment	30
Table 3-20	Digital I/O connector X7 – Pin assignment	31
Table 3-21	Analog I/O connector X8 – Pin assignment	31
Table 3-22	USB connector X13 – Pin assignment	32
Table 3-23	EtherCAT IN connector X14 & EtherCAT OUT connector X15 – Pin assignment	33
Table 3-24	EvaBo DIP switch SW1 – Digital input level	34
Table 3-25	Voltage outputs – Source	35
Table 3-26	Voltage outputs – Specifications	35
Table 3-27	Prefab maxon cables	37
Table 3-28	EPOS4 MB Micro EtherCAT 3-axes Connector Set – Content	38
Table 3-29	Recommended tools	38
Table 3-30	Power supply connector X1 – Pin assignment	40
Table 3-31	Logic supply connector X2 – Pin assignment	40
Table 3-32	Motor connector X3_1 / X3_2 / X3_3 – Pin assignment for maxon DC motor	41
Table 3-33	Motor connector X3_1 / X3_2 / X3_3 – Pin assignment for maxon EC motor	41
Table 3-34	Hall sensor connector X4_1 / X4_2 / X4_3 – Pin assignment	42
Table 3-35	Encoder/Sensor combo connector X5/X6_1 / X5/X6_2 / X5/X6_3 – Pin assignment	43
Table 3-36	Digital I/O connector X7_1 / X7_2 / X7_3 – Pin assignment	44
Table 3-37	Analog I/O connector X8_1 / X8_2 / X8_3 – Pin assignment	45
Table 3-38	USB connector X13_1 / X13_2 / X13_3 – Pin assignment	46
Table 3-39	EtherCAT IN connector X14 & EtherCAT OUT connector X15 – Pin assignment	47
Table 3-40	MoBo/Compact DIP switch SW1 – Settings	49
Table 3-41	Power supply – Pin assignment	50

Table 3-42	Power supply requirements	50
Table 3-43	Logic supply – Pin assignment	51
Table 3-44	Logic supply requirements	51
Table 3-45	DC motor – Pin assignment	52
Table 3-46	EC motor – Pin assignment	52
Table 3-47	Hall sensor – Pin assignment	53
Table 3-48	Hall sensor specification	53
Table 3-49	Encoder – Pin assignment	54
Table 3-50	Differential encoder specification	55
Table 3-51	Single-ended encoder specification	56
Table 3-52	SSI absolute encoder – Pin assignment	57
Table 3-53	SSI absolute encoder specification (Micro)	57
Table 3-54	SSI absolute encoder specification (EvaBo)	58
Table 3-55	SSI absolute encoder specification (MoBo)	58
Table 3-56	High-speed digital I/Os – Pin assignment	59
Table 3-57	Differential high-speed digital input specification	60
Table 3-58	Single-ended high-speed digital input specification (Micro)	60
Table 3-59	Single-ended high-speed digital input specification (EvaBo)	60
Table 3-60	Single-ended high-speed digital input specification (MoBo)	61
Table 3-61	High-speed digital output specification (EvaBo)	61
Table 3-62	High-speed digital output specification (EvaBo)	61
Table 3-63	High-speed digital output specification (MoBo)	62
Table 3-64	Digital inputs – Pin assignment – Micro	63
Table 3-65	Digital input specification – Micro	63
Table 3-66	Digital inputs – Pin assignment – EvaBo	64
Table 3-67	Digital input specification – Logic level setting	64
Table 3-68	Digital input specification – PLC level setting	65
Table 3-69	Digital outputs – Pin assignment – Micro	66
Table 3-70	Digital output specification	66
Table 3-71	Digital output – Sinks	67
Table 3-72	Digital output – Source	67
Table 3-73	Analog I/Os – Pin assignment	68
Table 3-74	Analog input specification	68
Table 3-75	Analog output specification	69
Table 3-76	USB interface specification	69
Table 3-77	Power Cable	70
Table 3-78	Power Cable High Current	70
Table 3-79	Motor Cable	70
Table 3-80	Hall Sensor Cable	71
Table 3-81	Encoder Cable	71
Table 3-82	Sensor Cable 5x2core	71
Table 3-83	Adapter Cable Encoder CLIK-Mate to DIN41651	72
Table 3-84	Adapter Cable Encoder CLIK-Mate to DIN41651 DIP switch SW1 – Settings	73
Table 3-85	Signal Cable 8core	73

Table 3-86	Signal Cable 7core	73
Table 3-87	USB Type A - micro B Cable	74
Table 3-88	Ethernet Cable	74
Table 3-89	NET Status LEDs	76
Table 3-90	Device Status LEDs	76
Table 3-91	EtherCAT Port LED	77
Table 4-92	EtherCAT status LEDs	85
Table 4-93	EtherCAT status LED "sinks"	85
Table 4-94	EtherCAT port LEDs	86
Table 4-95	EtherCAT port activity LED "source"	86
Table 4-96	Motherboard Design Guide – Recommended components	89
Table 4-97	Motherboard Design Guide – Grounding	90
Table 5-98	Designation of connectors and PCB marking	93
Table 5-99	Possible combinations of feedback signals for DC motor	96
Table 5-100	Possible combinations of feedback signals for EC (BLDC) motor	97

INDEX

A

abbreviations used 8
 alerts 6
 analog inputs 68
 analog outputs 69
 applicable EU directive 21
 applicable regulations 9

B

BLDC motor connection 22, 52

C

C1 (capacitor) 80
 cables (prefab)
 Adapter Cable Encoder CLIK-Mate to DIN41651 72
 Encoder Cable 71
 Ethernet Cable 74
 Hall Sensor Cable 70
 Motor Cable 70
 Power Cable 70
 Power Cable High Current 70
 Sensor Cable 5x2core 71
 Signal Cable 7core 73
 Signal Cable 8core 73
 USB Type A - micro B Cable 74

choke, motor 82

configuration of axes 49

connector set 25, 38

connectors

X1
 EvaBoard 27
 MoBo & Compact 40
 X13
 EvaBoard 32
 Micro 32
 MoBo & Compact 46
 X14
 EvaBoard 33
 MoBo & Compact 47
 X15
 EvaBoard 33
 MoBo & Compact 47
 X2
 EvaBoard 27
 MoBo & Compact 40
 X3
 EvaBoard 28
 MoBo & Compact 41
 X4
 EvaBoard 29
 MoBo & Compact 42
 X5
 EvaBoard 29
 X5/X6

MoBo & Compact 43

X6
 EvaBoard 30

X7
 EvaBoard 31
 MoBo & Compact 44

X8
 EvaBoard 31
 MoBo & Compact 45

country-specific regulations 9

D

D1 (DVS diode) 80
 D2 (DVS diode) 81
 DC motor connection 22, 52
 device condition, display of 75
 digital high-speed inputs (differential) 60
 digital high-speed inputs (single-ended) 60, 61
 digital high-speed output 61, 62
 digital inputs 63
 digital outputs 66
 DIP switch SW1 Adapter (693573) 72
 DIP switch SW1 Compact (684519) 48
 DIP switch SW1 EvaBo (638677) 34
 DIP switch SW1 MoBo (659508) 48
 DIP switch SW2 EvaBo 35

E

EC motor connection 22, 52

encoders

 absolute 57, 58
 differential 55
 serial 57, 58
 single-ended 56

EPOS4 Connector Set 25

EPOS4 MB Micro EtherCAT 3-axes Connector Set 38

ESD 9

ESD protection circuitry for MoBo 87

EU directive, applicable 21

F

footprint 91

FU1 (input fuse) 80

H

Hall sensor 53

how to

 calculate the required supply voltage 50
 get help in designing the motherboard 79
 interpret icons (and signs) used in this document 6

I

incorporation into surrounding system 21

informatory signs 6

inputs

- analog 68
- digital 63
- high-speed digital 60

interfaces

- EtherCAT 33, 47
- location and designation 94, 95
- USB 32, 46

internal motor chokes 82

L

LEDs

- EtherCAT port activity 86
- EtherCAT status 85

LEDs, interpretation of 75

logic supply 51

M

mandatory action signs 6

MoBo, ESD protection circuitry 87

motor choke 82

motor types, supported 8

N

naming of components 8

notations used 6

O

operating license 21

outputs

- analog 69
- digital 66
- high-speed digital 61, 62

P

part numbers

- 275829 70
- 275851 70
- 275878 70
- 275934 71
- 403968 74
- 422827 74
- 520850 70
- 520852 71
- 520853 73
- 520854 73
- 520859 25
- 638677 8, 24
- 654731 8
- 659508 8, 36
- 677324 88
- 684519 8, 36
- 691408 38
- 693573 72

performance data 11

power supply 50

precautions 9

prerequisites prior installation 21

prohibitive signs 6

protective measures (ESD) 9

purpose

- of the device 8
- of the document 5

R

regulations, applicable 9

RS422 84

RS422 transceiver 84

S

safety alerts 6

safety first! 9

serial encoder 57

signs used 6

spacer (mount) 79

SSI absolute encoder 57, 58

SSI encoder, wiring 102, 103

standards, fulfilled 19

standoff (mount) 79

status LEDs 75

supply voltage, required 50

switches

- SW1, Adapter (693573) 72
- SW1, Compact (684519) 48
- SW1, EvaBo (638677) 34
- SW1, MoBo (659508) 48
- SW2, EvaBo (638677) 35

symbols used 6

T

technical data 11

U

USB port 32, 46

W

wiring examples

- additional inductance on Motherboard 82
- DC motor 100
- digital incremental encoder 101, 102, 103
- DigOUT 67
- EC (BLDC) motor 101
- Hall sensors 101
- power & logic supply 100
- SSI encoder 102, 103



EtherCAT® is a registered trademark and patented technology, licensed by Beckhoff Automation GmbH, Germany

© 2026 maxon. All rights reserved. Any use, in particular reproduction, editing, translation, and copying, without prior written approval is not permitted (contact: maxon international ltd., Brünigstrasse 220, CH-6072 Sachseln, +41 41 666 15 00, www.maxongroup.com). Infringements will be prosecuted under civil and criminal law. The mentioned trademarks belong to their respective owners and are protected under trademark laws. Subject to change without prior notice.