

# EC 20 flat **iE**

## OPERATING MANUAL



## TABLE OF CONTENTS

<b>1</b>	<b>ABOUT</b>	<b>4</b>
1.1	About this Document. . . . .	4
1.2	About the Device. . . . .	6
1.3	About the Safety Precautions . . . . .	7
<b>2</b>	<b>SPECIFICATIONS</b>	<b>8</b>
2.1	Technical Data . . . . .	8
2.2	Operating Range. . . . .	10
2.3	Limitations. . . . .	10
2.4	Dimensional Drawings . . . . .	11
2.5	Standards . . . . .	12
<b>3</b>	<b>FUNCTIONAL DESCRIPTION</b>	<b>13</b>
3.1	Inputs and Outputs . . . . .	13
3.2	Protective Functions . . . . .	19
<b>4</b>	<b>INSTALLATION</b>	<b>20</b>
4.1	General Rules . . . . .	20
4.2	EMC-compliant Installation . . . . .	21
4.3	Mounting . . . . .	21
4.4	Wiring . . . . .	22
<b>5</b>	<b>OPERATION</b>	<b>24</b>
5.1	Troubleshooting . . . . .	24
5.2	Maintenance . . . . .	24

### READ THIS FIRST

***These instructions are intended for qualified technical personnel. Prior commencing with any activities...***

- you must carefully read and understand this manual and
- you must follow the instructions given therein.

***The EC 20 flat iE is considered as partly completed machinery according to EU Directive 2006/42/EC, Article 2, Clause (g) and is intended to be incorporated into or assembled with other machinery or other partly completed machinery or equipment.***

***Therefore, you must not put the device into service,...***

- unless you have made completely sure that the other machinery fully complies with the EU directive's requirements!
- unless the other machinery fulfills all relevant health and safety aspects!
- unless all respective interfaces have been established and fulfill the herein stated requirements!

<b>LIST OF FIGURES</b>	<b>25</b>
<b>LIST OF TABLES</b>	<b>26</b>
<b>INDEX</b>	<b>27</b>

# 1 ABOUT

## 1.1 About this Document

### 1.1.1 Intended Purpose

The purpose of the present document is to familiarize you with the EC 20 flat iE. It will highlight the tasks for safe and adequate installation and/or commissioning. Follow the described instructions ...

- to avoid dangerous situations,
- to keep installation and/or commissioning time at a minimum,
- to increase reliability and service life of the described equipment.

The present document is part of a documentation set and contains performance data and specifications, information on fulfilled standards, details on connections and pin assignment, and wiring examples.

### 1.1.2 Target Audience

The present document is intended for trained and skilled personnel. It conveys information on how to understand and fulfill the respective work and duties.

### 1.1.3 How to use

Throughout the document, the following notations and terms will be used.

Notation	Meaning
(n)	refers to an item (such as part numbers, list items, etc.)
→	denotes “see”, “see also”, “take note of” or “go to”

Table 1-1 Notation used

Term	Meaning
<b>Direction</b> CW / CCW	Indicates the direction of rotation of the motor shaft: <ul style="list-style-type: none"><li>• CW: Rotor turning to the right (clockwise) when looking towards the mounting flange</li><li>• CCW: Rotor turning to the left (counterclockwise) when looking towards the mounting flange</li></ul>
<b>Ingress protection</b> IP 00 / IP 40	The IP code (Ingress Protection Code) classifies and rates the degree of protection provided by casings and enclosures against intrusion, dust, accidental contact, and water. <ul style="list-style-type: none"><li>• IP 00: No protection against access to dangerous parts. No protection against water.</li><li>• IP 40: Protected against access to dangerous parts with a wire, tool or similar smaller than Ø1 mm and against foreign objects smaller than Ø1 mm. No protection against water.</li></ul>

Table 1-2 Terms used

## 1.1.4 Symbols & Signs

In the course of the present document, the following symbols and signs will be used.







Type	Symbol	Meaning	
Safety alert	 (typical)	DANGER	Indicates an <b>imminent hazardous situation</b> . If not avoided, it <b>will result in death or serious injury</b> .
		WARNING	Indicates a <b>potential hazardous situation</b> . If not avoided, it <b>can result in death or serious injury</b> .
		CAUTION	Indicates a <b>probable hazardous situation</b> or calls the attention to unsafe practices. If not avoided, it <b>may result in injury</b> .
Prohibited action	 (typical)	Indicates a dangerous action. Hence, <b>you must not!</b>	
Mandatory action	 (typical)	Indicates a mandatory action. Hence, <b>you must!</b>	
Information		Requirement / Note / Remark	Indicates an activity you must perform prior continuing, or gives information on a particular item you need to observe.
		Best practice	Indicates an advice or recommendation on the easiest and best way to further proceed.
		Material Damage	Indicates information particular to possible damage of the equipment.

Table 1-3 Symbols and signs

## 1.1.5 Copyright

This document is protected by copyright. Any further use (including reproduction, translation, microfilming, and other means of electronic data processing) without prior written approval is not permitted. The mentioned trademarks belong to their respective owners and are protected under intellectual property rights. © 2020 maxon. All rights reserved. Subject to change without prior notice.

mmag | EC 20 flat iE Operating Manual | Edition 2020-10 | DocID rel9653

maxon motor ag  
Brünigstrasse 220 +41 41 666 15 00  
CH-6072 Sachseln www.maxongroup.com

## 1.2 About the Device

The EC 20 flat with integrated electronics is a brushless, speed-controlled 4-quadrant drive. It combines the advantages of a flat motor with the performance of an integrated, digital 4-quadrant servo controller. The electronics are based on the proven maxon «ESCON» platform.

The EC 20 flat iE is available as 2 Watt and 5 Watt variant, with or without cover. Catalog variants are offered as 5 wire versions with analog set value input and digital speed monitor. Depending on the version, an input for activation («Enable») or to set the sense of rotation («Direction») is available..

Order number		Variant	Output [W]
IP 40	IP 00		
688690	688710	«Enable» (Activation) / CW	2
688691	688711	«Direction» (CW/CCW)	2
688692	688712	«Enable» (Activation) / CW	5
688693	688713	«Direction» (CW/CCW)	5

Table 1-4 Available catalog versions

Among others, the EC 20 flat iE has the following features.

- 4 pole pairs
- Commutation with Hall sensors
- digital speed control
- Set value speed via analog signal
- Speed monitor/tacho output with frequency proportional to speed
- comprehensive protection system (protection against reverse polarity, overvoltage, undervoltage, blockage, transients, overtemperature monitoring of the electronics)

The EC 20 flat iE can be used in various application areas (examples are not exhaustive):

- Fans and ventilators
- Pumps
- Laboratory application
- Measuring systems
- Printers
- Analytical equipment
- or similar products



### **Intended use**

*The EC 20 flat iE may only be used as a component in electrical equipment or machinery and may only be put into operation as an integral part of such equipment or machinery. Any other use is not permitted.*

*The EC 20 flat iE may only be operated within the performance limits described in this document.*

### 1.3 About the Safety Precautions

- Make sure that you have read and understood the note “READ THIS FIRST” on page A-2!
- Do not engage with any work unless you possess the stated skills (→chapter “1.1.2 Target Audience” on page 1-4)!
- Refer to →chapter “1.1.4 Symbols & Signs” on page 1-5 to understand the subsequently used indicators!
- You must observe any regulation applicable in the country and/or at the site of implementation with regard to health and safety/accident prevention and/or environmental protection!



#### DANGER

##### **High voltage and/or electrical shock**

##### **Touching live wires causes death or serious injuries!**

- *Consider any power cable as connected to live power, unless having proven the opposite!*
- *Make sure that neither end of cable is connected to live power!*
- *Make sure that power source cannot be engaged while work is in process!*
- *Obey lock-out/tag-out procedures!*
- *Make sure to securely lock any power engaging equipment against unintentional engagement and tag it with your name!*



#### Requirements

- *Make sure that all associated devices and components are installed according to local regulations.*
- *Be aware that, by principle, an electronic apparatus cannot be considered fail-safe. Therefore, you must make sure that any machine/apparatus has been fitted with independent monitoring and safety equipment. If the machine/apparatus should break down, if it is operated incorrectly, if the control unit breaks down or if the cables break or get disconnected, etc., the complete drive system must return – and be kept – in a safe operating mode.*
- *Be aware that you are not entitled to perform any repair on components supplied by maxon.*



#### Electrostatic sensitive device (ESD)

- *Wear working cloth and use equipment in compliance with ESD protective measures.*
- *Handle device with extra care.*

## 2 SPECIFICATIONS

### 2.1 Technical Data

Parameter	Unit	2 Watt		5 Watt		
		IP 00 (688710) (688711)	IP 40 (688690) (688691)	IP 00 (688712) (688713)	IP 40 (688692) (688693)	
Drive data	Nominal power supply voltage [a]	VDC	24			
	Nominal speed [a]	rpm	6'000			
	Nominal torque (max. continuous torque)	mNm	3.55 [b]		7.31 [b]	
	Recommended speed control range	rpm	200...6'468			
	Acceleration and deceleration ramp	rpm/s	6'000			
	Maximum permissible drive speed	rpm	10'000			
	Maximum torque (short-time)	mNm	5.46		11.7	
	Maximum efficiency	%	51.5		62.1	
Electrical rating	Nominal supply voltage $V_{CC}$	VDC	10...26.4			
	Absolute supply voltage $+V_{min}$ / $+V_{max}$	VDC	8 / 28			
	Pulse width modulation frequency	kHz	50			
	Sampling rate PI speed controller	kHz	1 (1 ms)			
	Sampling rate analog input	kHz	1 (1 ms)			
Motor data	Max. motor voltage	VDC	$V_{CC} - 0.5$			
	Torque constant	mNm/A	8.4		18.1	
	Speed constant	rpm/V	1'140		527	
Mechanical data	Dimensions (LxWxH)	mm	17x23x26	18.1x23x26	21x23x26	22.1x23x26
	Weight	g	30		37	
	Mounting	—	Centering collar / flange / 3 frontal fixation threads M2			
	Rotor inertia	gcm <sup>2</sup>	3.2		5.1	
	Axial play at axial load	mm	<2 N: 0 / >2 N: 0.14			
	Radial play		Preloaded ball bearings			
	Max. axial load, dynamic	N	1.8			
	Max. radial load, 5 mm from flange	N	11		12	

Continued on next page.



Parameter	Unit	2 Watt		5 Watt		
		IP 00 (688710) (688711)	IP 40 (688690) (688691)	IP 00 (688712) (688713)	IP 40 (688692) (688693)	
Environment	Protection class	IP 40 IP 00				
	Operation temperature	-40...+40				
	Extended temperature range [b]	+40...+85				
	Storage temperature	-40...+85				
	Operation altitude [c]	0...3'000				
Inputs & Outputs	Digital input «Enable»	0...3.3 —	0...3.3 —	0...3.3 —	0...3.3 —	
	Digital input «Direction»	— 0...3.3	— 0...3.3	— 0...3.3	— 0...3.3	
	Digital output «Speed monitor»	3.3				
	Analog input «Set value speed»	Resolution 12-bit, 0.33...10.78 V; 1 kHz				
Thermal data	Thermal resistance housing/ambient	K/W <sup>-1</sup>	17.2	13	10.6	10.6
	Thermal resistance winding/housing	K/W <sup>-1</sup>	7.98	10	5.32	5.32
	Thermal time constant winding	s	3.5	4.38	3.68	3.68
	Thermal time constant motor	s	28.6	21.6	17.6	17.6
	Max. temperature of winding [d]	°C	125			
	Max. temperature of electronics [e]	°C	100			
Connections	5 wires	mm <sup>2</sup>	0.09 (AWG 28)			

- [a] Values at nominal speed and ambient temperature  $T_a = 25\text{ °C}$
- [b] Operation within the extended temperature range is permitted, whereby a respective derating will apply
- [c] Operating altitude in meters above Mean Sea Level, MSL
- [d] The winding **is not** protected against thermal overload by the electronics
- [e] The electronics **is** protected against thermal overload (→“Thermal Protection of the Electronics” on page 3-19)

Table 2-5 Technical data

## 2.2 Operating Range

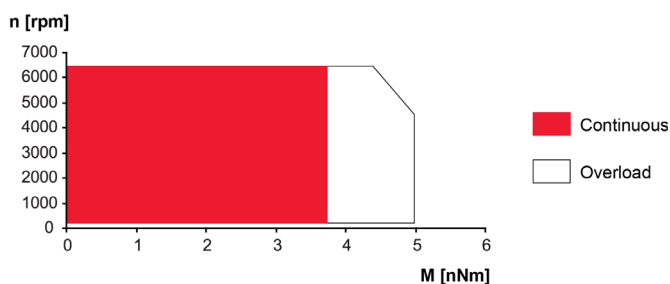

Table 2-6 Operating range – 2 Watt variant

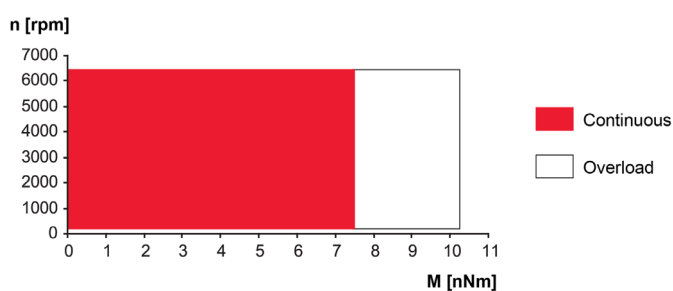

Table 2-7 Operating range – 5 Watt variant

### Continuous operation range

The drive can be operated with a speed control. Taking into account the given thermal resistance (→“Thermal data” on page 2-9) at an ambient temperature of 25°C, the drive does not exceed the maximum permissible operating temperatures.

### Overload range

The drive reaches the specified operating points. The speed may vary from the set value. In case of longer overload, the overload protection switches off the drive.

## 2.3 Limitations

Protective function	Switch-off threshold	Recovery threshold
Undervoltage	7.5 V	7.7 V
Overvoltage	29.5 V	28.5 V
Overcurrent	±1.5 A	—
Thermal overload	100 °C	90 °C

Table 2-8 Limitations

## 2.4 Dimensional Drawings

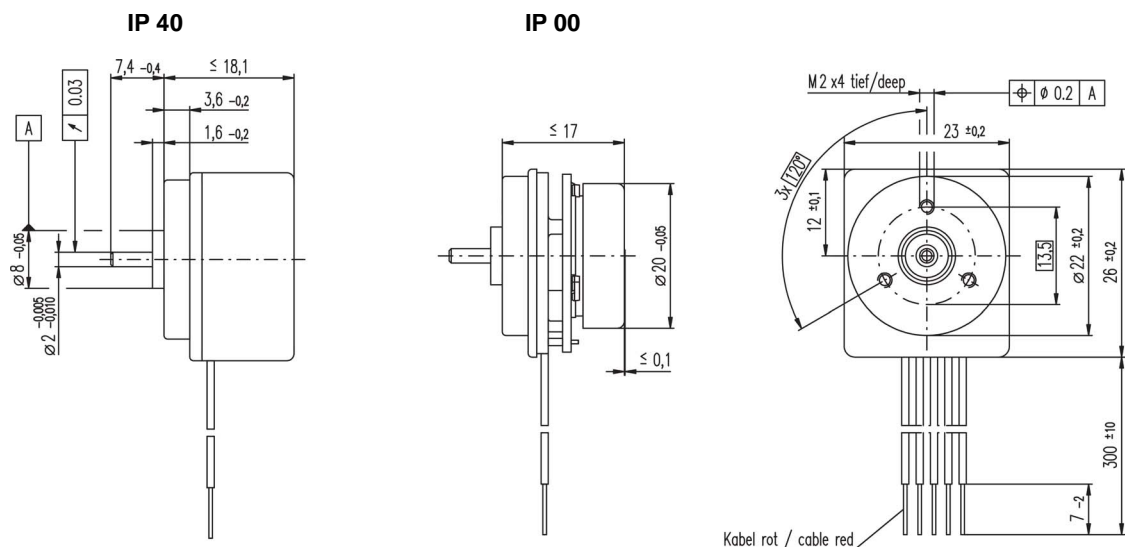

Figure 2-1 2 Watt version – Dimensional drawing [mm]

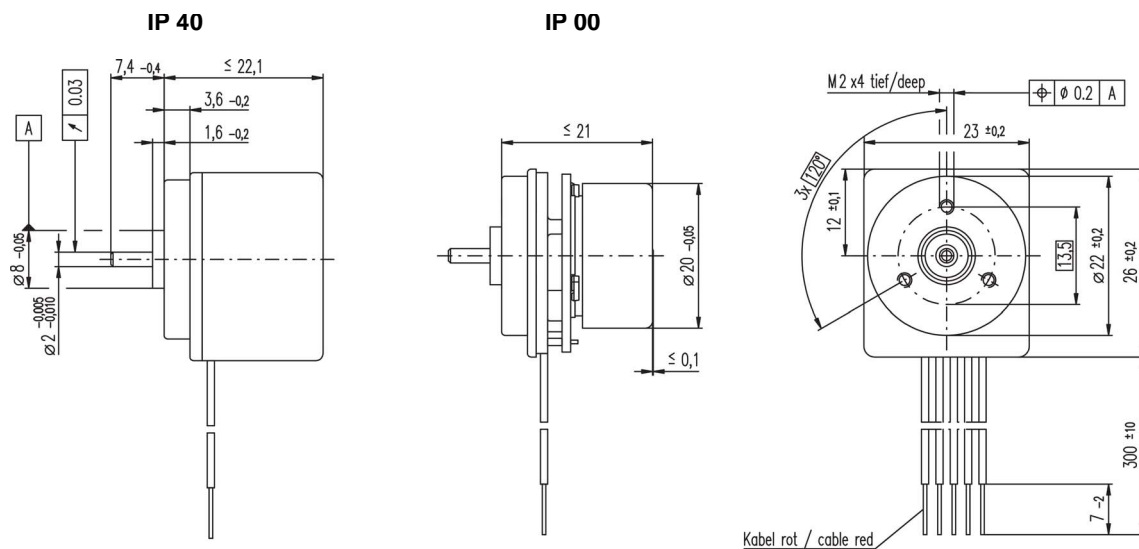

Figure 2-2 5 Watt version – Dimensional drawing [mm]

## 2.5 Standards

The described device has been successfully tested for compliance with the below listed standards. In practical terms, only the complete system (the fully operational equipment comprising all individual components, such as drive, power supply unit, EMC filter, cabling etc.) can undergo an EMC test to ensure interference-free operation.



**Important notice on the EMC-compliant installation**

*The device's compliance with the mentioned standards does not imply its compliance within the final, ready to operate setup. In order to achieve compliance of your operational system, you must perform EMC testing of the involved equipment as a whole.*

Standards		
Electromagnetic compatibility	IEC/EN 61000-6-2	Immunity for industrial environments
	IEC/EN 61000-6-3	Emission standard for residential, commercial and light-industrial environments
Environment	IEC/EN 60068-2-6	Environmental testing – Test Fc: Vibration (sinusoidal, 10...500 Hz, 20 m/s <sup>2</sup> )
	MIL-STD-810F	Random transport (10...500 Hz up to 2.53 g <sub>rms</sub> )
Safety	UL File Number	E108467; unassembled printed circuit board

Table 2-9 Standards

### 3 FUNCTIONAL DESCRIPTION

#### 3.1 Inputs and Outputs

##### 3.1.1 Input «Set value speed»

The motor speed is set with an analog voltage at the input «Speed set value». The input is protected against overvoltage.

Pin assignment	Connection wire white (AWG 28)
Input voltage	0...+10.78 V (referenced to GND)
Max. input voltage	±30 VDC
Input resistance	98 kΩ (in range of 0...+12.2 V) 68 kΩ (in range of +12.2...+30 V)
A/D converter	12-bit

Table 3-10 Input «Set value speed» – Specifications

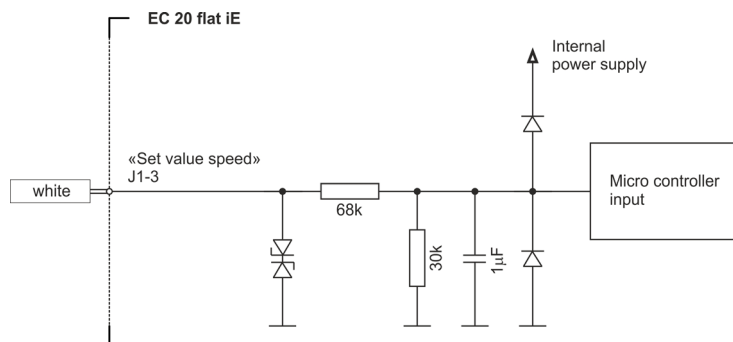

Figure 3-3 Input «Set value speed» – Internal circuitry

The set speed is regulated by the controller. Changes to the speed set value are restricted by the set acceleration ramp (→“Electrical rating” on page 2-8).

In order to activate the motor, the voltage at the input «Set value speed» must be at least 0.17 V. With the «Enable» version, additionally the corresponding input must be activated (→chapter “3.1.2 Input «Enable» (Activation)” on page 3-16).

Continued on next page.

The following set value ranges are distinguished:

Set value	Function	Remarks
0...0.17 V	«Disable»	Power stage disabled
0.17...0.33 V	Operation at minimal speed (200 rpm)	«Enable» version: if the input «Enable» is activated
0.33...10.78 V	Linear speed setting between 200 and 6'468 rpm $V_{aim} = \frac{n_{aim}}{600}$	In speed range 200...300 rpm, the regulation accuracy of the speed controller is limited. The speed may considerably differ from the set value depending on load and supply voltage.

$V_{aim}$  Set value voltage [V]

$n_{aim}$  Desired speed [rpm]

Table 3-11 Input «Set value speed» – Set value ranges

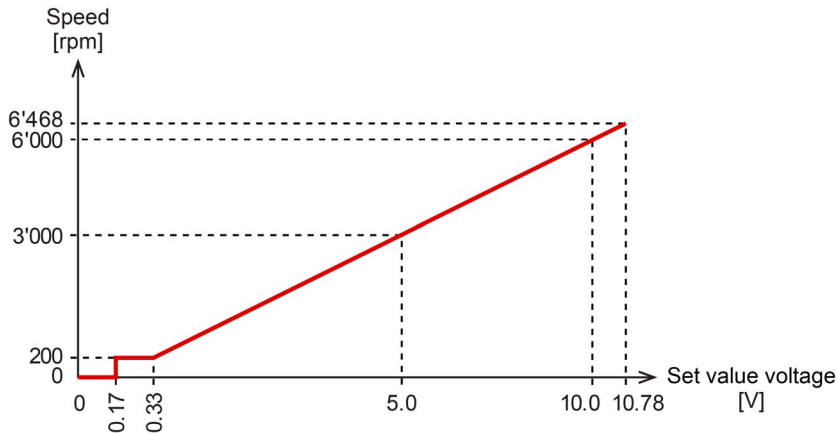

Figure 3-4 Input «Set value speed» – Gradient

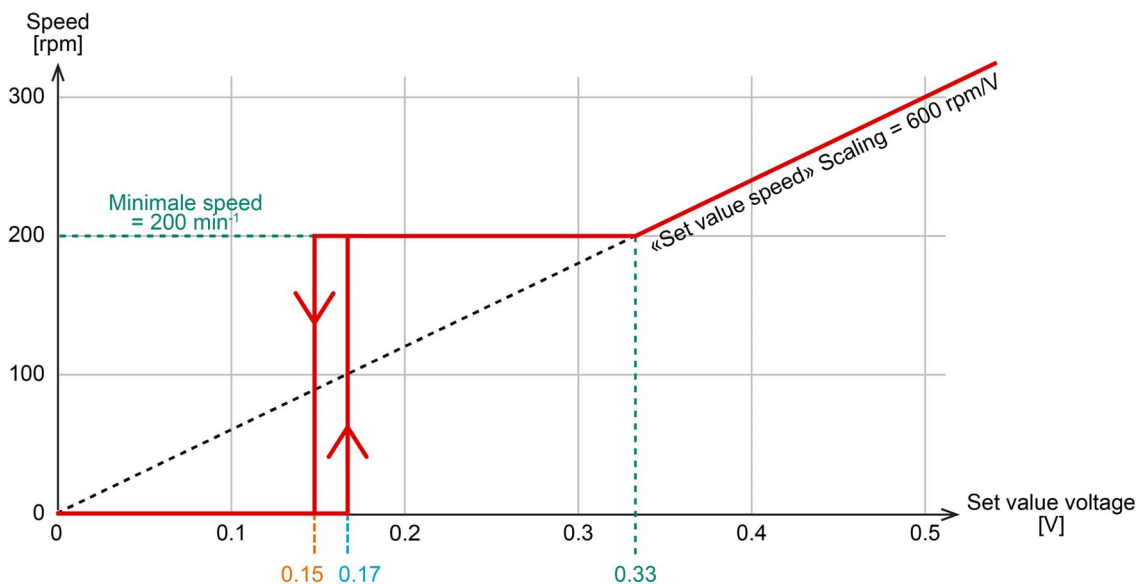

Figure 3-5 Input «Set value speed» – Switch on/switch off hysteresis (detail)



### Setting the speed set value by PWM signal

The speed set value can alternatively be preset by a PWM signal with fixed frequency and amplitude. The desired set speed value change is obtained by variation of the duty cycle in range of 0...100%. Both, amplitude and duty cycle thereby have an effect on the resulting speed. The average of the applied PWM signal corresponds to the analog input signal of the speed set value.

Pin assignment	Connection wire white (AWG 28)
Input voltage	0...+10.78 V (referenced to GND)
Max. input voltage (amplitude)	±30 VDC
Frequency range	500 Hz...20 kHz
Modulation range	0...100%

Table 3-12 Input «Set value speed» – PWM settings

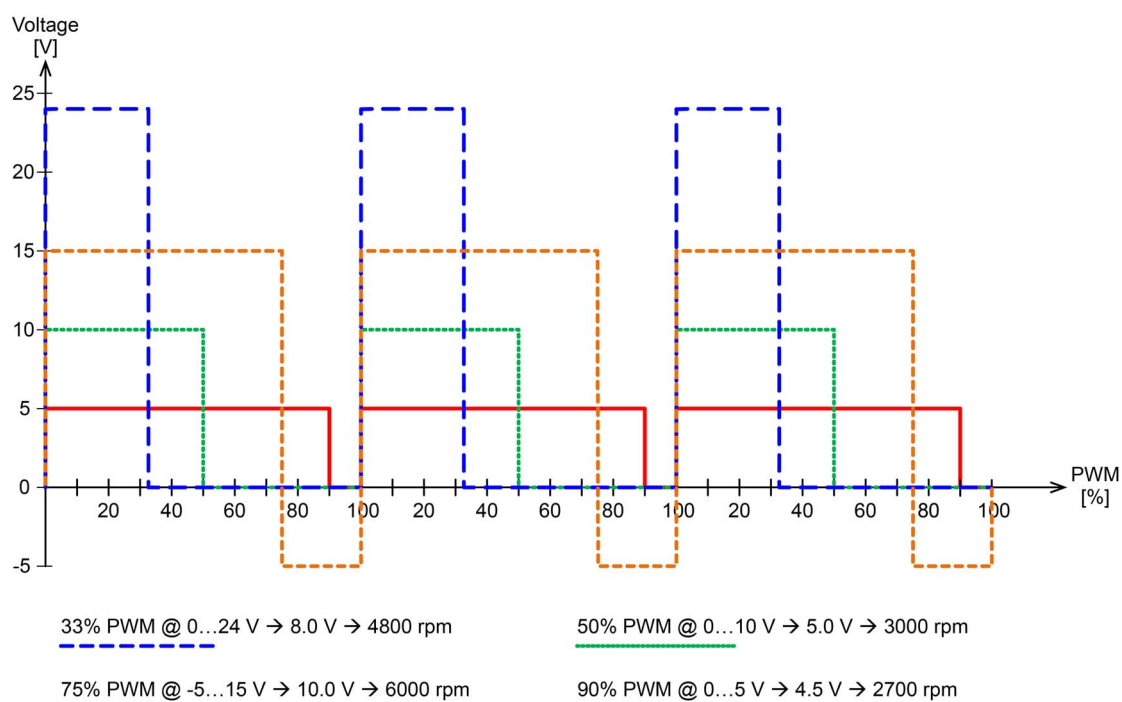

Figure 3-6 Input «Set value speed» – Examples for possible PWM level control

### 3.1.2 Input «Enable» (Activation)

The power stage is activated with the digital input «Enable». It is protected against overvoltage.

Pin assignment	Connection wire grey (AWG 28)
Input voltage	0...+3.3 V (referenced to GND)
Max. input voltage	±30 VDC
Logic 0 «Disable»	<0.8 V
Logic 1 «Enable»	>2.4 V
Input resistance	130 kΩ (in range of 0...+4.3 V) 10 kΩ (in range of +4.3...+30 V)

Table 3-13 Input «Enable» – Specifications

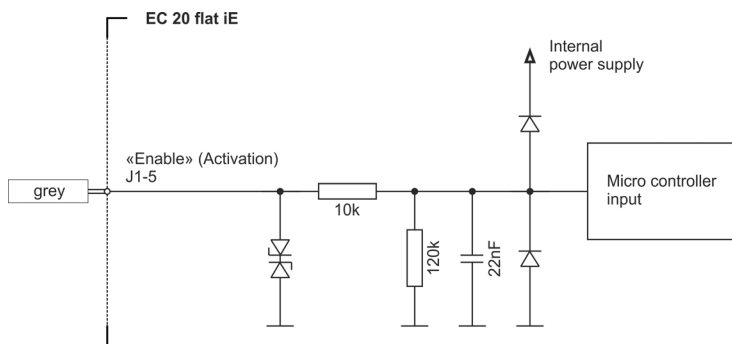

Figure 3-7 Input «Enable» – Internal circuitry



### 3.1.3 Input «Direction» (CW/CCW)

The direction of rotation (CW/CCW) will be determined by digital input «Direction».

If the direction of rotation is changed during operation, the motor runs down freely until reaching minimal speed, then accelerates in opposite direction of rotation.

Pin assignment	Connection wire grey (AWG 28)
Input voltage	0...+3.3 V (referenced to GND)
Max. input voltage	±30 VDC
Logic 0 «Disable»	<0.8 V
Logic 1 «Enable»	>2.4 V
Input resistance	130 kΩ (in range of 0...+4.3 V) 10 kΩ (in range of +4.3...+30 V)

Table 3-14 Input «Direction» – Specifications

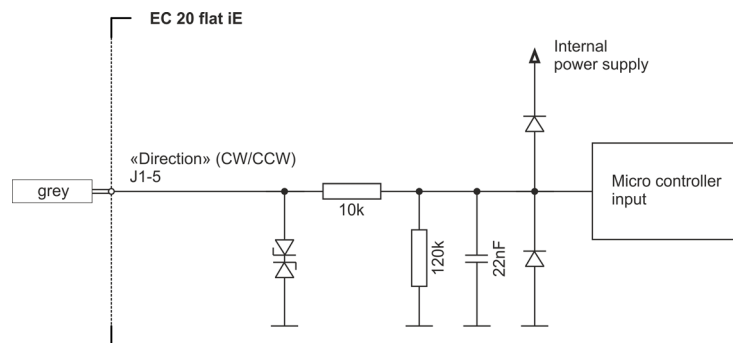

Figure 3-8 Input «Direction» – Internal circuitry

The direction of rotation «CW» will be activated by a voltage above 2.4 V. The speed is dependent on the voltage at the input «Set value speed». . The power stage will be deactivated with a voltage below 0.17 V at the speed set value input. The motor runs down freely.

### 3.1.4 Output «Speed monitor» (Monitor n)

The actual speed of the motor shaft can be monitored at the output «Speed monitor». It is available as digital signal (High/Low) and delivers 6 pulses per mechanical turn.

The output «Speed monitor» is also available in «Disable» state.

Pin assignment	Connection wire green (AWG 28)
Output voltage	0...+3.3 V (referenced to GND)
Overvoltage protection (continuous)	±30 VDC
Logic 0 «Disable»	>0.5 V (without load)
Logic 1 «Enable»	<2.8 V (without load)
Output resistance	4.1 kΩ
Duty cycle	50%
Frequency at speed monitor output	$f_{monitor} = \frac{n_{actual}}{10}$ $n_{actual} = 10 \cdot n$

$f_{monitor}$  Frequency at speed monitor output [Hz]

$n_{actual}$  Speed [rpm]

Table 3-15 Output «Speed monitor» – Specifications

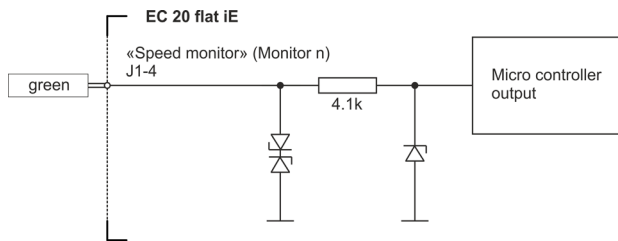

Figure 3-9 Output «Speed monitor» – Internal circuitry

## 3.2 Protective Functions

The EC 20 flat iE is equipped with the following protective devices:

### INVERSE POLARITY PROTECTION

The supply voltage  $V_{CC}$  is protected against polarity reversal. Thereby, the negative input voltage must not exceed the maximum permitted supply voltage  $V_{CC}$ .

### UNDERVOLTAGE SWITCH-OFF

The power stage is switched off when the supply voltage  $V_{CC}$  drops below 7.5 V.

If the supply voltage exceeds the restart threshold of 7.7 V, the EC 20 flat iE will be again ready for operation.

### OVERVOLTAGE SWITCH-OFF

The power stage is switched off when the supply voltage  $V_{CC}$  exceeds 29.5 V.

If the supply voltage drops below the restart threshold of 28.5 V, the EC 20 flat iE will be again ready for operation.

### BLOCKAGE PROTECTION

If the rotor locks for at least two seconds, the power stage is deactivated for four seconds. After that the power stage is activated again.

### THERMAL PROTECTION OF THE ELECTRONICS

The power stage is switched off if the PCB temperature exceeds 100°C. As soon as the PCB temperature has dropped below 90°C, the EC 20 flat iE will be again ready for operation.



---

### **Possible permanent damage to the motor**

The motor winding is **not** protected against thermal overload. To avoid defects, the motor may only be operated within the permissible operating ranges (→chapter "2.2 Operating Range" on page 2-10).

---

### CURRENT LIMITING

The winding current is electronically limited to 650 mA. This also limits the maximum load torque accordingly.

If the motor shaft comes to a standstill due to activated current limiting, the blockage protection engages after two seconds.

## 4 INSTALLATION



### **Important notice**

**The EC 20 flat iE is considered as partly completed machinery according to EU Directive 2006/42/EC, Article 2, Clause (g) and is intended to be incorporated into or assembled with other machinery or other partly completed machinery or equipment. The following prerequisites must be fulfilled before you are permitted to commence with the installation.**

### 4.1 General Rules



#### **WARNING**

##### **Risk of injury**

**Operating the device without the full compliance of the surrounding system with the EU Directive 2006/42/EC may cause serious injuries**

- Do not operate the device, unless you have made completely sure that the other machinery fully complies with the EU directive's requirements!
- Do not operate the device, unless the other machinery fulfills all relevant health and safety aspects!
- Do not operate the device, unless all respective interfaces have been established and fulfill the requirements stated in this document!



#### **WARNING**

##### **Risk of injury**

**Unintentional operation or automatic start-up can lead to serious injury**

- Make sure that the surrounding system is protected from automatic start-up!
- Make sure to apply all necessary safeguards against unintentional operation!



##### **Maximal permitted supply voltage**

- Make sure that supply power is between 8...28 DC.
- Supply voltages above 30 VDC will destroy the unit.
- Note that the necessary output current is depending on the load torque. Yet, the output current limit of the EC 20 flat iE for continuous operation is at max. 650 mA.



##### **Possible irreversible damage of motor**

- Until completion of the installation, individual components can be permanently damaged by improper handling. Therefore, handle the components with particular care.
- Point the cable outlet preferably downwards.
- Handle connection cables with special care! – Do not kink. Do not bend. Do not route around sharp edges. Do not strain.



##### **Electrostatic sensitive device (ESD)**

- Wear working cloth and use equipment in compliance with ESD protective measures.
- Handle device with extra care.

## 4.2 EMC-compliant Installation



---

**EMC conformity of the operational system**

Observe the note on page 2-12.

---

**CABLE LENGTH  $\leq$ 300 MM**

- Usually, no shielding is required.
- Star wiring recommended if several EC 20 flat are supplied by a common power supply.

**CABLE LENGTH  $>$ 30 MM**

- The voltage drop in the connection cable must be minimized by choosing a sufficiently large wire cross section.
- In electromagnetically harsh environments, use of shielded cables connected to ground at both ends can improve immunity against interferences.
- Release cable shielding on one side if 50/60 Hz interference problems occur.
- The incidence surface for interferences can be reduced by shortening the unshielded original connection cable.
- Immunity against interferences and speed stability in case of fluctuating loads can be accomplished by routing the set speed value signal separately in a shielded cable that is put to ground on both sides. In addition to the set speed value signal, a second ground (GND) line must also be carried in this separate cable, but only connected on the motor side. The external set value speed signal must be potential-free.

## 4.3 Mounting

For sufficient heat dissipation during operation, we recommend mounting on a metallic component.

The motor has a centering collar and frontal fixation threads in the flange.

When mounting output elements (e.g. pinion, shaft coupling), observe the maximum permissible axial and radial loads (→“Mechanical data” on page 2-8).

## 4.4 Wiring

### 4.4.1 Pin Assignment

#### VERSION «ENABLE»

Cable		Signal	Description
Wire	Color		
1	red	+V <sub>CC</sub>	Power supply voltage (+10...+26.4 VDC)
2	black	GND	Ground
3	white		Input «Set value speed» (0.33...10.78 VDC)
4	green		Output «Speed monitor» (6 impulses per turn)
5	grey		Input «Enable» • Enable: 2.4...3.3 VDC • Disable: 0...0.8 VDC

Table 4-16 Version «Enable» – Pin assignment

#### VERSION «DIRECTION»

Cable		Signal	Description
Wire	Color		
1	red	+V <sub>CC</sub>	Power supply voltage (+10...+26.4 VDC)
2	black	GND	Ground
3	white		Input «Set value speed» (0.33...10.78 VDC)
4	green		Output «Speed monitor» (6 impulses per turn)
5	grey		Input «Direction» • CW: 2.4...3.3 V • CCW: 0...0.8 V

Table 4-17 Version «Direction» – Pin assignment

### 4.4.2 Minimal Wiring

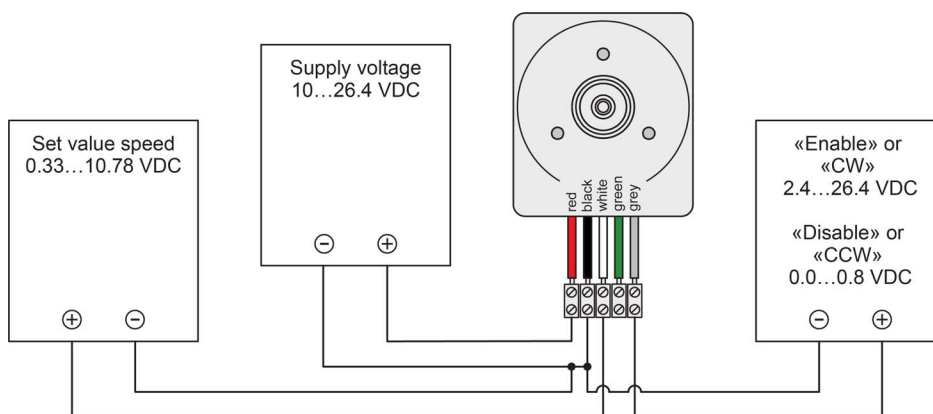

Figure 4-10 Speed set value and «Enable» or «Direction» with external power source

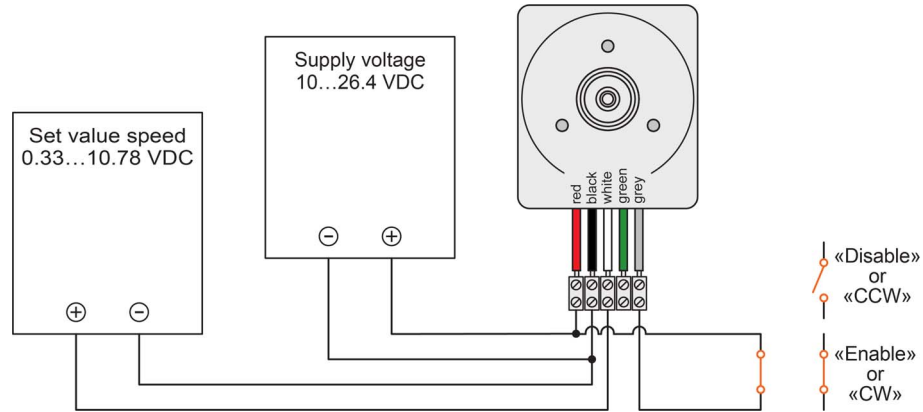

Figure 4-11 Speed set value with external power source and «Enable» or «Direction» with potential-free contact

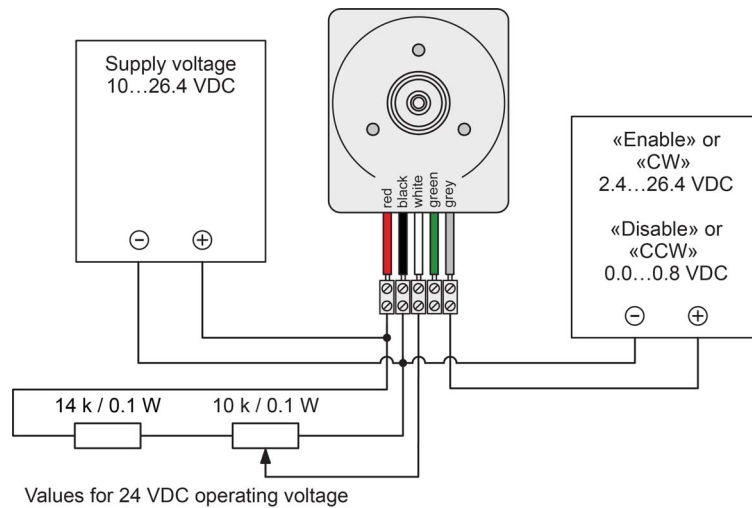

Figure 4-12 Speed set value with external potentiometer and «Enable» or «Direction» with external power source

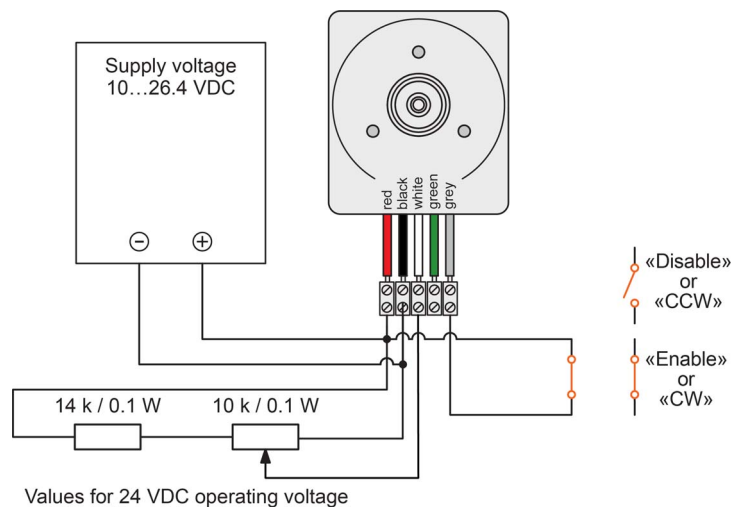

Figure 4-13 Speed set value with external potentiometer and «Enable» or «Direction» with potential-free contact

## 5 OPERATION

### 5.1 Troubleshooting

The following requirements must be met for trouble-free operation:

Prerequisite for operation	
<b>Motor shaft</b>	The motor shaft is not blocked and can run freely
<b>Power supply</b>	The supply voltage $V_{CC}$ is connected (red "+", black "-")
	The supply voltage $V_{CC}$ is switched on and between 10.0...26.4 VDC
<b>Set value speed</b>	The set value voltage is connected (white "+", black "-")
	The set value voltage is switched on and between 0.33...10.78 VDC
<b>«Enable» (Activation)</b>	The activation voltage is connected (grey "+", black "-")
	With activation via a potential-free contact: <ul style="list-style-type: none"> <li>• The grey wire is directly connected to the power supply (red "+") via a switch</li> <li>• The switch is closed</li> </ul>
<b>Sense of rotation</b>	The motor's direction of rotation depends on the voltage applied to the «Direction» input (→ page 3-17). <ul style="list-style-type: none"> <li>• CCW (counterclockwise direction, left): 0...0.8 V</li> <li>• CW (clockwise direction, right): 2.4...3.3 V</li> </ul>

Table 5-18 Troubleshooting

### 5.2 Maintenance



**The EC 20 flat iE does not contain any user-serviceable parts.**

The EC 20 flat iE is designed for demanding long term use and is maintenance-free. Nevertheless, please contact our Service Center if any malfunction should occur.

→ <https://support.maxongroup.com/>



## LIST OF FIGURES

Figure 2-1	2 Watt version – Dimensional drawing [mm] . . . . .	11
Figure 2-2	5 Watt version – Dimensional drawing [mm] . . . . .	11
Figure 3-3	Input «Set value speed» – Internal circuitry . . . . .	13
Figure 3-4	Input «Set value speed» – Gradient . . . . .	14
Figure 3-5	Input «Set value speed» – Switch on/switch off hysteresis (detail) . . . . .	14
Figure 3-6	Input «Set value speed» – Examples for possible PWM level control . . . . .	15
Figure 3-7	Input «Enable» – Internal circuitry . . . . .	16
Figure 3-8	Input «Direction» – Internal circuitry . . . . .	17
Figure 3-9	Output «Speed monitor» – Internal circuitry . . . . .	18
Figure 4-10	Speed set value and «Enable» or «Direction» with external power source . . . . .	22
Figure 4-11	Speed set value with external power source and «Enable» or «Direction» with potential-free contact . . . . .	23
Figure 4-12	Speed set value with external potentiometer and «Enable» or «Direction» with external power source . . . . .	23
Figure 4-13	Speed set value with external potentiometer and «Enable» or «Direction» with potential-free contact . . . . .	23

**LIST OF TABLES**

Table 1-1	Notation used . . . . .	4
Table 1-2	Terms used . . . . .	4
Table 1-3	Symbols and signs . . . . .	5
Table 1-4	Available catalog versions . . . . .	6
Table 2-5	Technical data . . . . .	9
Table 2-6	Operating range – 2 Watt variant . . . . .	10
Table 2-7	Operating range – 5 Watt variant . . . . .	10
Table 2-8	Limitations . . . . .	10
Table 2-9	Standards . . . . .	12
Table 3-10	Input «Set value speed» – Specifications . . . . .	13
Table 3-11	Input «Set value speed» – Set value ranges . . . . .	14
Table 3-12	Input «Set value speed» – PWM settings . . . . .	15
Table 3-13	Input «Enable» – Specifications . . . . .	16
Table 3-14	Input «Direction» – Specifications . . . . .	17
Table 3-15	Output «Speed monitor» – Specifications . . . . .	18
Table 4-16	Version «Enable» – Pin assignment . . . . .	22
Table 4-17	Version «Direction» – Pin assignment . . . . .	22
Table 5-18	Troubleshooting . . . . .	24

## INDEX

### A

alerts 5  
applicable regulations 7  
autions 7

### B

blockage protection 19

### C

country-specific regulations 7  
current limiting 19  
CW / CCW 4

### D

Direction (input) 17  
direction of rotation, definition of 4

### E

EMC-compliant installation 21  
Enable (input) 16  
ESD protection 20

### I

informatory signs 5  
ingress protection 4  
inputs (functional description) 13  
intended use 6  
inverse polarity protection 19  
IP code 4

### M

mandatory action signs 5  
minimal wiring 22

### N

notations used 4

### O

operation, prerequisites for 24  
order numbers 6  
outputs (functional description) 13  
overvoltage switch-off 19

### P

performance data 8  
precautions 7  
prerequisites  
    for operation 24  
    prior installation 20  
prohibitive signs 5  
protection against ingress 4  
protective features, internal 19  
protective measures (ESD) 20  
purpose  
    of the device 6  
    of the document 4

### R

regulations, applicable 7

### S

safety alerts 5  
Set value speed (input) 13  
signs used 5  
Speed monitor (output) 18  
standards, fulfilled 12  
symbols used 5

### T

technical data 8  
temperature monitoring 19  
terms used 4  
thermal protection 19  
troubleshooting 24

### U

undervoltage switch-off 19  
use, intended 6

### V

versions 6

This document is protected by copyright. Any further use (including reproduction, translation, microfilming, and other means of electronic data processing) without prior written approval is not permitted. The mentioned trademarks belong to their respective owners and are protected under intellectual property rights.

© 2020 maxon. All rights reserved. Subject to change without prior notice.  
mmag | EC 20 flat iE Operating Manual | Edition 2020-10 | DocID rel9653

maxon motor ag  
Brünigstrasse 220  
CH-6072 Sachseln

+41 41 666 15 00  
[www.maxongroup.com](http://www.maxongroup.com)