

# EC frameless DT 50 M Ø54 mm, brushless, 150 watt

Dynamic Torque

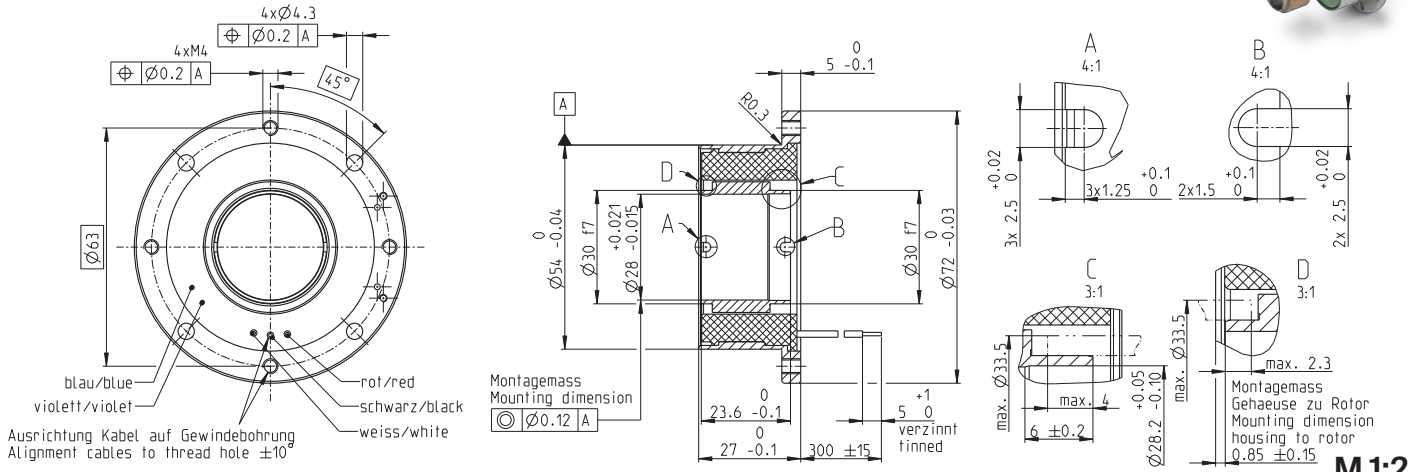

EC frameless DT



M 1:2

- Stock program
- Standard program
- Special program (on request)

## Part Numbers

without Hall sensors	758031
----------------------	--------

Motor Data		
<b>Values at nominal voltage</b>		
1 Nominal voltage	V	48
2 No load speed	rpm	4470
3 No load current	mA	127
4 Nominal speed	rpm	3780
5 Nominal torque	mNm	416
6 Nominal current (max. continuous current)	A	3.8
7 Stall torque	mNm	3130
8 Stall current	A	63.3
9 Max. efficiency	%	91.2
<b>Characteristics</b>		
10 Terminal resistance phase to phase	Ω	0.758
11 Terminal inductance phase to phase	mH	0.619
12 Torque constant	mNm/A	102
13 Speed constant	rpm/V	93.5
14 Speed/torque gradient	rpm/mNm	0.694
15 Mechanical time constant	ms	0.71
16 Rotor inertia	gcm <sup>2</sup>	98.8

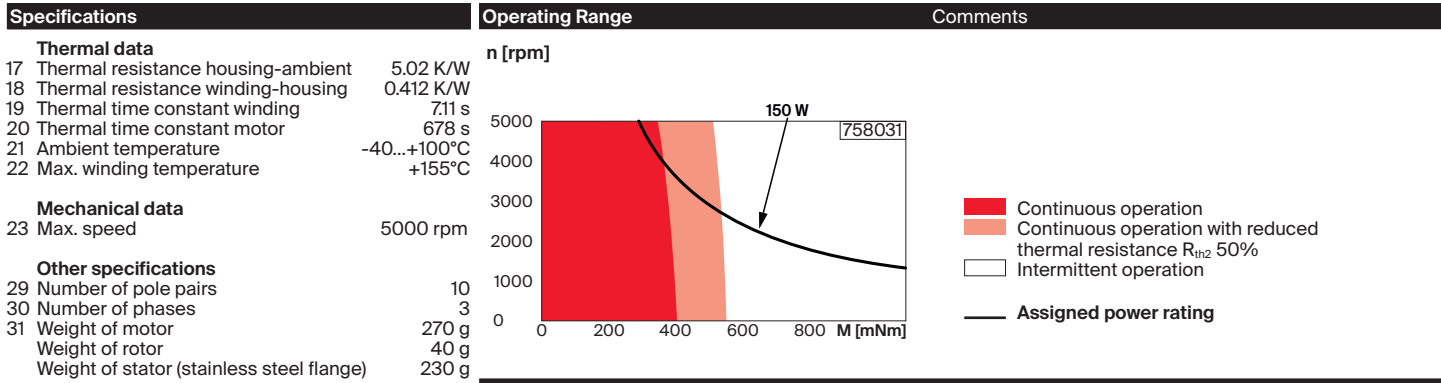

Modular System	Details on catalog page 54
<p>Values listed in the table are nominal.</p> <p><b>Connection motor</b> (Cable AWG 18)                      red Motor winding 1                      black Motor winding 2                      white Motor winding 3</p> <p><b>Connection NTC</b> (Cable AWG 24)                      purple NTC                      blue NTC                      Resistance 25°C: 5 kΩ ±1%, beta (25–85°C): 3490 K</p> <p><b>Comment</b>                      For Torque control data, refer to "Installation Manual" available on maxon online shop.</p>	<p><b>Sensor</b>                      521_ TSX 50 MAG with Hall sensors</p> <p><b>Motor Control</b>                      551_ES CON Module 50/5                      553_ES CON 50/5                      561_EPO S4 Micro 24/5 C AN                      561_EPO S4 Micro 24/5 E therCAT                      562_EPO S4 Module 50/5                      565_EPO S4 Compact 50/5                      567_EPO S4 50/5                      568_EPO S4 Disk 60/8 C AN                      568_EPO S4 Disk 60/8 E therCAT</p>

Variants
Aluminum flange (-70 g) on request
Without flange: maxon integration on request