

EC 20 flat brushless, 5 watt, with integrated electronics

4-Q-Speed Controller

EC flat

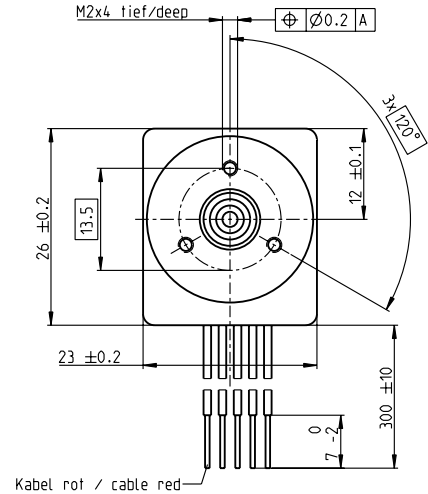
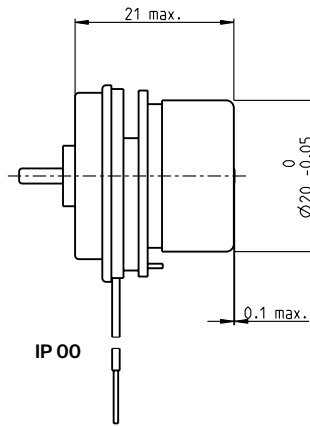
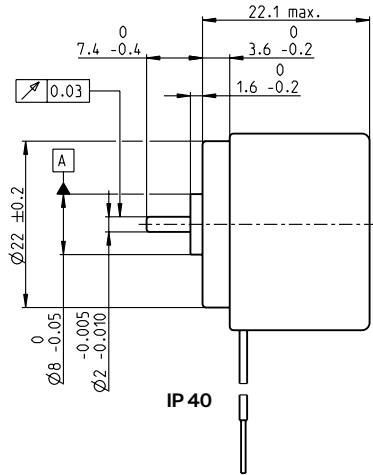

M 1:1

- Stock program
- Standard program
- Special program (on request)

Part Numbers

5 wire version	
Enable	Direction
IP 40 (with cover) 688692	688693
IP 00 (without cover) 688712	688713

Motor Data

Values at nominal voltage			
1 Nominal voltage	V	24	24
2 No load speed	rpm	6000	6000
3 No load current	mA	32.9	32.9
4 Nominal speed	rpm	6000	6000
5 Nominal torque (max. continuous torque)	mNm	7.31	7.31
6 Nominal current (max. continuous current)	A	0.377	0.377
33 Max. torque	mNm	13.2	13.2
34 Max. current	A	0.73	0.73
9 Max. efficiency	%	54	54
Characteristics			
35 Type of control		Speed	Speed
36 Supply voltage +V _{CC}	V	10...28	10...28
37 Speed set value input	V	0.33...10.8	0.33...10.8
38 Scale speed set value input	rpm/V	600	600
39 Speed range	rpm	200...6480	200...6480
40 Max. acceleration	rpm/s	6000	6000

Specifications

Thermal data	
17 Thermal resistance housing-ambient	10.6 K/W
18 Thermal resistance winding-housing	5.32 K/W
19 Thermal time constant winding	3.66 s
20 Thermal time constant motor	13.9 s
21 Ambient temperature	-40...+85°C
22 Max. winding temperature	+125°C
41 Max. temperature of electronics	+105°C
Mechanical data (preloaded ball bearings)	
16 Rotor inertia	5.1 gcm ²
24 Axial play at axial load < 2.0 N	0 mm
> 2.0 N	0.14 mm
25 Radial play	preloaded
26 Max. axial load (dynamic)	1.8 N
27 Max. force for press fits (static) (static, shaft supported)	26 N
28 Max. radial load, 5 mm from flange	12 N

Operating Range

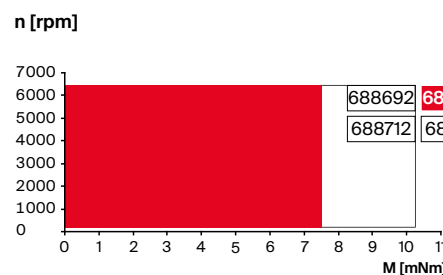

Comments

- Continuous operation**
The drive can be operated with a speed controller and, taking account of the given thermal resistance (fig. 17 and 18) at an ambient temperature of 25°C, does not exceed the maximum permissible operating temperatures.
- Overload range**
The drive reaches these operating points. Speed may vary from the set value. The overload protection shuts down the drive in the event of sustained overload.

Other specifications

31 Weight of motor	37 g
32 Direction of rotation	Clockwise (CW)

Values listed in the table are nominal.

Protective functions

Overload protection, blockage protection, inverse-polarity protection, thermal overload protection, low/high voltage cut-off

Connection 5 wire version (Cable AWG 28)

red	+V _{CC} 10...28 VDC
black	GND
white	Speed set value input
green	Monitor n (6 pulses per revolution)
grey	Disable (Type Enable) or sense of direction (Type Direction)

maxon Modular System

Details on catalog page 46

Planetary Gearhead

Ø22 mm
0.5-2.0 Nm
Page 383/386

