

The outstanding technical features of **maxon DC motors**:

- No magnetic cogging
- High acceleration thanks to a low mass inertia
- Low electromagnetic interference
- Low inductance
- High efficiency
- Linearity between voltage and speed
- Linearity between load and speed
- Linearity between load and current
- Small torque ripple thanks to multi-segment commutator
- Able to bear high overloads for short periods
- Compact design – small dimensions
- Multiple combination possibilities with gears as well as DC tachometers and encoders

Characteristics of the **maxon DCX** range:

- High power density
- High-quality DC motor with NdFeB magnet
- High speeds and torques
- Robust design (metal flange)
- Easily configured online
- Fast delivery

Characteristics of the **maxon DC-max** range:

- High-performance at low cost
- Combines rational manufacturing and design of the A-max motors with the higher power density of the NdFeB magnets
- Automated manufacturing process
- Easily configured online
- Fast delivery

Characteristics of the **maxon RE** range:

- High power density
- High-quality DC motor with NdFeB magnet
- High speeds and torques
- Robust design (metal flange)

Characteristics of the **maxon A-max** range:

- Good price-performance ratio
- DC motor with AlNiCo magnet
- Automated manufacturing process

Turning speed

The optimal operating speeds are between 4000 rpm and 9000 rpm depending on the motor size. Speeds of more than 20 000 rpm have been attained with some special versions.

A physical property of a DC motor is that, at a constant voltage, the speed is reduced with increasing loads. A good adaptation to the desired conditions is possible thanks to a variety of winding variants.

At lower speeds, a gear combination is often more favorable than a slowly turning motor.

Program

- **DCX**
- **DC-max**
- **RE**
- **A-max**

The maxon winding

The “heart” of the maxon motor is the world-wide patented ironless winding, System maxon. This motor principle has very specific advantages. There is no magnetic detent and minimal electromagnetic interference. The efficiency of up to 90% exceeds that of other motor systems.

There are numerous winding variants for each motor type (see motor data sheets). They are differentiated by the wire diameter and number of turns. This results in various motor terminal resistances. The wire sizes used are between 32 µm and 0.45 mm, resulting in the different terminal resistances of the motors.

This influences the motor parameters that describe the transformation of electrical and mechanical energy (torque and speed constants). It allows you to select the motor that is best suited to your application.

Effects of wire gauge and number of windings are:

Low terminal resistance

- Low resistance winding
- Thick wire, few turns
- High starting currents
- High specific speed (rpm per volt)

High terminal resistance

- High resistance winding
- Thin wire, many turns
- Low starting currents
- Low specific speed (rpm per volt)

The maximum permissible winding temperature in high-temperature applications is 125°C (155°C in special cases), otherwise 100°C or 85°C.

- 1 Flange, front
- 2 Permanent magnet
- 3 Housing (magnetic return)
- 4 Shaft
- 5 Winding
- 6 Commutator plate
- 7 Commutator
- 8 Graphite brushes
- 9 Precious metal brushes
- 10 Cover
- 11 Electrical connection
- 12 Ball bearing
- 13 Sintered sleeve bearing
- 14 Flange, rear

Service life

A general statement about service life cannot be made due to many influencing factors. Service life can vary between more than 20 000 hours under favorable conditions, and less than 100 hours under extreme conditions (in rare cases). Roughly 1000 to 3000 hours are attained with average requirements.

The following have an influence:

- 1. The electric load:** higher current loads result in greater electric wear. Therefore, it may be advisable to select a somewhat stronger motor for certain applications. We would be happy to advise you.
- 2. Speed:** the higher the speed, the greater the mechanical wear.
- 3. Type of operation:** extreme start/stop, left/right operation leads to a reduction in service life.
- 4. Environmental influences:** temperature, humidity, vibration, type of installation, etc.
- 5. In the case of precious metal brushes, the CLL concept** increases service life at higher loads and the benefits of precious metal brushes are retained.
- 6. Combinations of graphite brushes** and ball bearings lead to a long service life, even under extreme conditions.

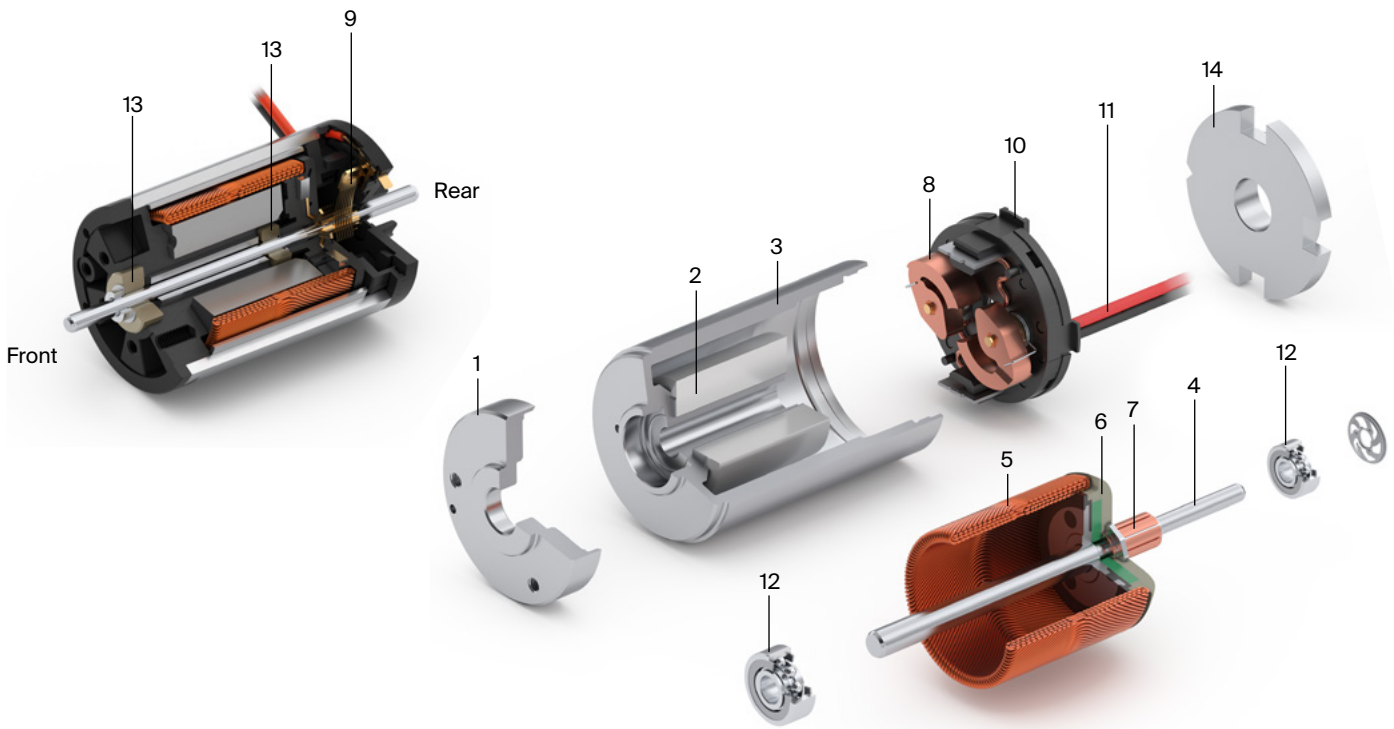

Mechanical commutation

Graphite brushes

In combination with copper commutators for the most rigorous applications. More than 10 million cycles were attained in different applications.

Graphite brushes are typically used:

- In larger motors
- With high current loads
- In start/stop operation
- In reverse operation
- While controlling at pulsed power stage (PWM)

The special properties of **graphite brushes** can cause so-called spikes. They are visible in the commutation pattern. Despite the high-frequency interference caused by the spikes, these motors have become popular in applications with electronic controls. Please note, that the contact resistance of the graphite brushes changes dependent on load.

Precious metal brushes and commutator

Our precious metal combinations ensure a highly constant and low contact resistance, even after a prolonged standstill time. The motors work with very low starting voltages and electromagnetic interferences.

Precious metal brushes are typically used:

- In small motors
- In continuous operation
- With small current loads
- With battery operation
- In DC tachometers

The commutation pattern is uniform and free of spikes, as opposed to that of other motors. The combination of precious metal brushes and maxon rotor system results in minimum of high-frequency interference, which otherwise leads to major problems in electrical circuits. The motors need practically no interference suppression.

CLL concept

With precious metal commutation, the wear on commutators and brushes is caused mainly by sparks. The CLL concept suppresses spark generation to a large extent, thus greatly extending service life. When driven with a pulsed power stage (PWM) higher no load currents occur and an unwanted motor heating can result. Additional inductance (chokes) in the motor supply lines help.

For further explanations, please see page 92 or "The selection of high-precision microdrives" by Dr. Urs Kafader.

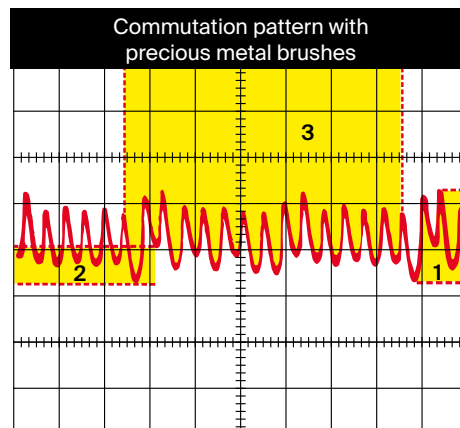
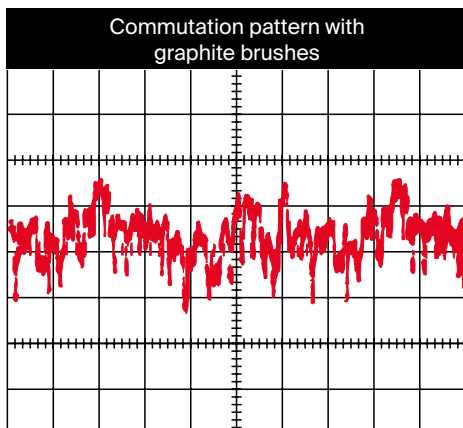

Commutation pattern

The commutation pattern shows the current pattern of a maxon DC motor over one motor revolution.

Please place a low-ohm series resistor in series with the motor (approx. 50 times smaller than the motor resistance). Observe the voltage drop over the resistor on the oscilloscope.

Legend

- 1 Ripple, actual peak-to-peak ripple
- 2 Modulation, attributable mainly to asymmetry in the magnetic field and in the winding.
- 3 Signal pattern within a revolution (number of peaks = twice the number of commutator segments)