

# ECX SPEED 19 M Ø19 mm, brushless, BLDC motor

Sterilizable

Key Data: 60/65 W, 11.1 mNm, 70 000 rpm



ECX SPEED

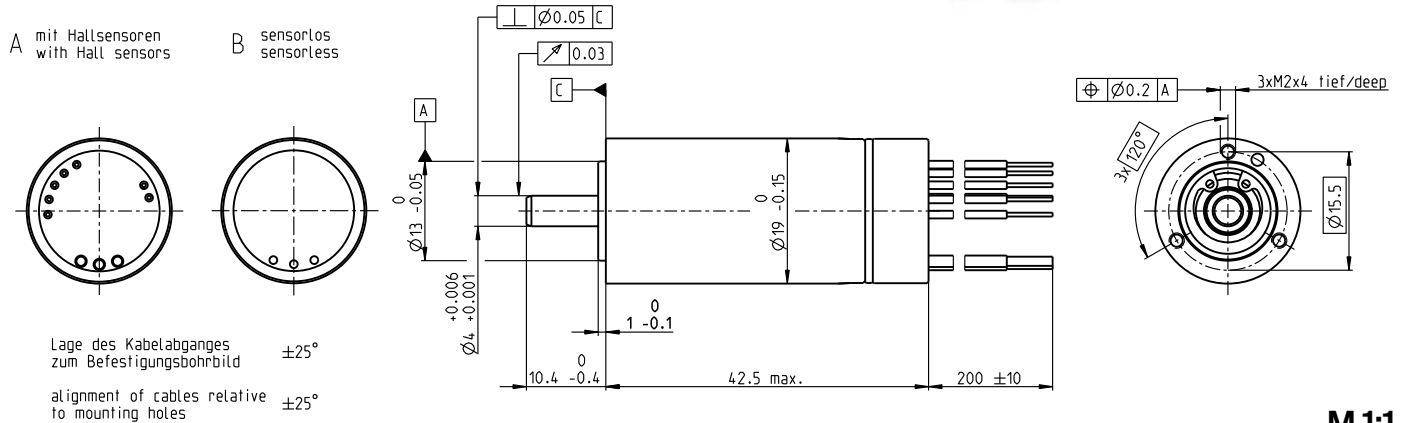

M 1:1

### Motor Data

1_	Nominal voltage	V	18	24	36	48
2_	No load speed	rpm	64800	64600	64600	63400
3_	No load current	mA	207	155	103	75.3
4_	Nominal speed	rpm	59800	59500	59700	58600
5_	Nominal torque (max. continuous torque)	mNm	11.1	9.77	10.1	10.3
6_	Nominal current (max. continuous current)	A	4.32	2.87	1.98	1.48
7_	Stall torque	mNm	179	150	164	169
8_	Stall current	A	67.7	42.4	31	23.5
9_	Max. efficiency	%	89.4	88.4	88.9	89.1
10_	Terminal resistance	Ω	0.266	0.566	1.16	2.04
11_	Terminal inductance	mH	0.0234	0.0438	0.0986	0.182
12_	Torque constant	mNm/A	2.64	3.53	5.3	7.2
13_	Speed constant	rpm/V	3610	2700	1800	1330
14_	Speed/torque gradient	rpm/mNm	363	433	396	376
15_	Mechanical time constant	ms	4.38	5.22	4.77	4.53
16_	Rotor inertia	gcm <sup>2</sup>	1.15	1.15	1.15	1.15

### Thermal data

17_	Thermal resistance housing-ambient	K/W	16.8
18_	Thermal resistance winding-housing	K/W	1.6
19_	Thermal time constant winding	s	2.36
20_	Thermal time constant motor	s	696
21_	Ambient temperature	°C	-40...+135
22_	Max. winding temperature	°C	155

### Operating Range

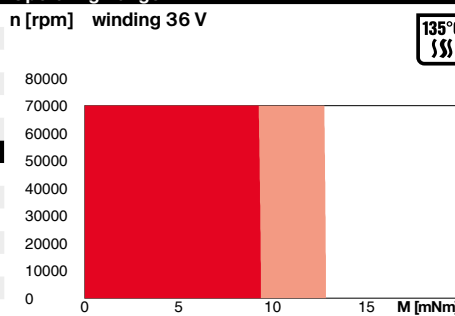

### Sterilization information

135°C SSS

Sterilization cycles  
Sensorless: typical 2000  
Hall sensors: typical 1000

Sterilization with steam  
Temperature +134°C ±4°C  
Compression pressure up to 2.3 bar  
Rel. humidity 100%  
Cycle length 18 min.

Continuous operation  
 Continuous operation with reduced thermal resistance R<sub>th2</sub> 50%  
 Short term operation

### Mechanical data ball bearings

23_	Max. speed	rpm	70 000
24_	Axial play	mm	0...0.29
	Preload	N	4
	Direction of force		pull
25_	Radial play		preloaded
26_	Max. axial load (dynamic)	N	4
27_	Max. force for press fits (static) (static, shaft supported)	N	70 5000
28_	Max. radial load [mm from flange]	N	12 [5]

### Other specifications

29_	Number of pole pairs	1
30_	Number of phases	3
31_	Weight of motor	g 78
32_	Typical noise level [rpm]	dBA 48 [50 000]

### maxon Modular System

maxon gear	Stages [opt.]	maxon sensor	maxon motor control
348_GPX 19 SPEED 1-2		for motor type A:	501_ESCON 36/3 EC
353_GPX 22 SPEED [3]		455_ENX 19 EASY INT	501_ESCON Module 50/4 EC-S
		for motor type B:	501_ESCON Module 50/5
		455_ENX 19 EASY INT Abs.	503_ESCON 50/5
			505_DEC Module 50/5
			509_EPOS4 Micro 24/5
			510_EPOS4 Mod./Comp. 50/5
			511_EPOS4 Comp. 24/5 3-axes
			515_EPOS4 50/5
			516_EPOS4 Disk 60/8
			520_EPOS2 P 24/5

### Configuration

Flange front: thread holes/center thread  
Flange back: plastic ring/external thread/with opening  
Shaft front: length/diameter  
Electric connection: cable length/pin connection  
Temperature sensor: NTC-Thermistor (only for motor type A and only when not combined with an encoder).  
Appropriate connectors and connecting cables are available for the configuration of the pin connection together with the external thread: see catalog, Accessories section.

### Connection A and B, motor (Cable AWG 20)

red	Motor winding 1
black	Motor winding 2
white	Motor winding 3

### Connection A, sensors (Cable AWG 26)

orange	V <sub>Hall</sub> 3...24 VDC
blue	GND
yellow	Hall sensor 1
brown	Hall sensor 2
grey	Hall sensor 3

Wiring diagram for Hall sensors see page 57. In combination with the ENX EASY INT, the orange (V<sub>cc</sub>) and blue (GND) connections are not used. Hall signals are then generated by an ENX EASY-INT sensor (no pull-up resistor required; output signals: CMOS compatible push-pull stage).

### Connection NTC (Cable AWG 26)

purple	NTC
purple	NTC

Resistance 25°C: 10 kOhm ±1%, beta (25-85°C): 3490 K

xdrives.maxongroup.com